



Dear Sea Hunt Owner:

Welcome to the Sea Hunt owner's family! Buying and owning a boat is a very special experience. Of all the many products you'll ever own we want your Sea Hunt experience to be the absolute best. That means providing the descriptions, explanations and technical support that you need to enjoy your Sea Hunt with confidence and security.

The seaworthiness and safety of your Sea Hunt is highly dependent on the operation, maintenance and care of your boat, so please read this manual thoroughly and keep it around for reference. If you need further explanation or "hands-on" help, don't hesitate to ask the people at your Sea Hunt dealership; they have experience with the systems and operations of your boat. If for any reason you need additional help, please feel free to call us at the factory. We sincerely want to provide you with the help and information that will make your Sea Hunt experience delightful.

Thank you for choosing a Sea Hunt. All of us at the factory and at your dealership are dedicated to earning your confidence in Sea Hunt Boats. Again, welcome to the family.

Sincerely yours,

Bubba Roof  
President  
SEA HUNT BOATS, INC.

Sea Hunt Boats  
2348 Shop Road  
Columbia, SC 29201  
Phone: (803) 755-6539  
Fax: (803) 755-3399  
[www.seahuntboats.com](http://www.seahuntboats.com)

# TABLE OF CONTENTS

## OWNERS ORIENTATION

Orientation . . . . .	4	Leaving/Approaching the Dock . . . . .	24
Warranty Information . . . . .	4	Towing or Being Towed . . . . .	24
Areas for Dealer Assistance . . . . .	4	Shallow Water . . . . .	24
Hazard Warning Symbols . . . . .	5	Anchoring . . . . .	25
Dealer Pre-delivery/Delivery Responsibilities . . . . .	6	Using a Windlass . . . . .	25
Consumer Responsibilities . . . . .	6	General Information on Boat Handling . . . . .	26
Boat Model Identification . . . . .	7	Common Nautical Terms . . . . .	27
Registration Numbers . . . . .	7		

## BOATING SAFETY

Required Safety Equipment . . . . .	8		
Fire Extinguisher . . . . .	8		
Personal Flotation Device (PFD) . . . . .	8		
Sound Signaling Devices . . . . .	8		
Visual Distress Signals . . . . .	8		
Lighting . . . . .	8		
Additional Recommended Equipment . . . . .	9		
Emergency Information . . . . .	10		
Fire, Swamping/Capsizing . . . . .	10		
Collision/Weather . . . . .	11		
Emergency Stop Switch . . . . .	12		
Rendering Assistance . . . . .	12		
Accident Reporting . . . . .	12		
Boating Safety Tips . . . . .	12		
Basic Rules of the Road . . . . .	14		
Loading Capacity . . . . .	16		
Carbon Monoxide . . . . .	16		
Suggested Boating Classes and Literature . . . . .	17		

## GENERAL BOATING INFORMATION

Fuel System Information . . . . .	18		
Fueling . . . . .	19		
Discharge Regulations . . . . .	20		
Discharge of Oil . . . . .	20		
Disposal of Plastics and Other Waste . . . . .	20		
Driving . . . . .	21		
Trailing . . . . .	21		
Pre-start Checklist . . . . .	23		

## PERFORMANCE

Performance Factors . . . . .	28		
Engine Efficiency . . . . .	28		
Weather Conditions . . . . .	28		
Load Distribution . . . . .	28		
Marine Growth . . . . .	28		
Trim . . . . .	28		
Propeller . . . . .	29		
Propeller Terms . . . . .	29		
Outboard Propulsion System . . . . .	29		
Engine Systems . . . . .	30		
Engine Warranty . . . . .	30		
Throttle/Shift Control . . . . .	30		
Neutral Safety . . . . .	30		
Shift Function . . . . .	30		
Throttle Function . . . . .	30		
Forward Throttle . . . . .	30		
Reverse Throttle . . . . .	31		
Neutral Throttle . . . . .	31		
Stopping/Braking . . . . .	31		
Control Cables . . . . .	31		
Steering . . . . .	31		
Hydraulic Steering . . . . .	32		
Trim Tabs . . . . .	32		
Engine Lubrication . . . . .	32		

## GAUGES AND SWITCHES

Yamaha Digital Displays . . . . .	33		
Tachometer . . . . .	33		
Speedometer . . . . .	33		
Fuel Gauge . . . . .	33		
Usable Fuel . . . . .	33		

# TABLE OF CONTENTS

Voltmeter . . . . .	34
Trim Gauge . . . . .	34
Warning Systems . . . . .	34
Water Temperature and Oil Level . . . . .	34
Low Fuel Warning Indicator . . . . .	34
Overheat Warning Indicator . . . . .	34
Oil Level Warning . . . . .	34
Switch Panel . . . . .	35
Bilge Pump . . . . .	35
Cockpit Lights . . . . .	35
Horn . . . . .	35
Livewell . . . . .	35
Washdown . . . . .	35
Navigation/Anchor Lights . . . . .	35
Accessory . . . . .	35
Circuit Breakers . . . . .	35

## MAINTENANCE & SERVICE

General . . . . .	36
Exterior Fiberglass Finish . . . . .	36
Maintenance . . . . .	36
Cleaning . . . . .	36
Waxing . . . . .	36
Repairing . . . . .	37
Bottom Paint . . . . .	38
Canvas . . . . .	38
Canvas Care . . . . .	38
Zippers & Snaps . . . . .	39
Clear Vinyl . . . . .	40
Storage . . . . .	40
Upholstery . . . . .	41
Hardware Mounting . . . . .	41
Caulking/Gasket . . . . .	41
Stainless Steel Rails & Hardware . . . . .	41
Acrylic & Plexiglass . . . . .	41
Corrosion and Rust . . . . .	42
Anodized Aluminum Components . . . . .	43
Leaning Posts, Rod Holders, T-Top Frames . . . . .	43
Scuppers . . . . .	43
Fuel System Maintenance . . . . .	43
Fuel Tank Compartment . . . . .	44
Batteries . . . . .	44
Battery Switch . . . . .	45

## WINTERIZATION AND STORAGE

General Information . . . . .	46
Boat Storage . . . . .	46
Winterization and Storage . . . . .	47
Cleaning and Lubricating the Boat . . . . .	47
Draining and Water Systems . . . . .	47
Fuel System . . . . .	48
Batteries . . . . .	48
Engines . . . . .	48
Storage Checklist . . . . .	49
Commissioning Boat After Storage . . . . .	49
Prior to Launching . . . . .	50
After Launching . . . . .	50
Water Systems . . . . .	51
Head systems . . . . .	52
Electrical systems . . . . .	54

## ELECTRICAL DIAGRAMS

6 Circuit Instrument Panel and Harness . . . . .	57
8 Circuit Instrument Panel and Harness . . . . .	58
Escape Instrument Panel and Harness . . . . .	59
Ultra 219-245 and BX Harness . . . . .	60
Gamefish 25 and Ultra 265 Harness . . . . .	61
Gamefish 27 and Ultra 275 Harness . . . . .	62
Gamefish 28-30 and Ultra 275-305 Harness . . . . .	63
Trolling Motor Wiring . . . . .	64

## SAFETY LABELS

ON-PLANE SEATING LOCATIONS . . . . .	66
--------------------------------------	----

LIMITED WARRANTY . . . . .	67
----------------------------	----

SERVICE / MAINTENANCE LOG . . . . .	68-70, inside back cover
-------------------------------------	-----------------------------

# OWNERS ORIENTATION

## ORIENTATION

Your Sea Hunt has many features and accessories that are addressed in printed material provided by the various equipment manufacturers. This information is compiled in a package that we will reference throughout this manual. Consult your Sea Hunt Owner's Manual, Yamaha manuals, as well as the others included in your owner's package for advice on proper operation, maintenance intervals, specifications, warranties, and other useful information. There are also increasing numbers of manufacturers that do not provide any comprehensive printed information but instead provide online or built-in electronic manuals. This is especially true for electronics such as chartplotters and depth sounders.

While reading your Sea Hunt Owner's Manual, you will also find other technical literature referenced as outside resources for more detailed information. Your Owner's Manual can also be used to record other boat specifics such as maintenance records and additional equipment and accessories installed after delivery.

## WARRANTY INFORMATION

The Sea Hunt warranty is located on the last page of this manual. Upon the purchase of your new Sea Hunt boat, the dealer will fill out a warranty card. This card will be kept on file at the dealership and at the Sea Hunt factory. A copy will be provided for your records and should be kept with other valuable documents for future reference. For questions regarding your warranty please contact your dealership.

## AREAS FOR DEALER ASSISTANCE

Your new Sea Hunt is built with pride and the utmost care is taken to make your ownership experience memorable. Every Sea Hunt goes through a rigorous quality control inspection throughout the entire manufacturing process. Subsequent to the final factory overview your dealer must perform additional pre-delivery checks and approve your Sea Hunt for delivery. Your dealer is always your first point of contact for any questions or concerns you may have about your boat.

## HAZARD WARNING SYMBOLS

The hazard warning symbols shown below are applied throughout this manual to alert the customer of potentially dangerous situations that can lead to product damage, personal injury and/or death. We urge you to observe these warnings and comply with all safety recommendations.

### **DANGER**

**DANGER** – Immediate hazards which **WILL** result in severe personal injury or death if the warning is ignored.

### **WARNING**

**WARNING** – Hazards or unsafe practices that **COULD** result in severe personal injury or death if the warning is ignored.

### **CAUTION**

**CAUTION** – Hazards or unsafe practices that could result in minor injury or product or property damage if the warning is ignored.

### **NOTICE**

**NOTICE** – Information which is important to proper operation or maintenance, but is not hazard related.

## **DEALER PRE-DELIVERY / DELIVERY RESPONSIBILITIES**

- Provide introduction and orientation to the general operation of your complete Sea Hunt package.
- A manufacturers warranty registration must be completed and signed by both the dealer and consumer to validate and activate applicable warranties.
- A review of all warranties, pointing out the importance of mailing warranty and registration to various manufacturers within the required time limits.
- An explanation of safety issues regarding the use of all systems and components.
- Guidance on acquiring local and out of area service during and after warranty periods.
- Review local and national regulations.

## **CONSUMER RESPONSIBILITIES**

- The following are responsibilities of the Sea Hunt owner:
- Read and understand the express limited warranty.
- Study all literature and instructions.
- Be familiar with local and national regulations (as well as international if you will be taking your boat more than 3 miles offshore).
- Examine the boat and confirm there is no physical damage and that all systems are working properly before accepting delivery.
- Following approximately 10-15 hours of operation, contact your selling dealer to schedule a 20 hour inspection service.
- Perform proper maintenance and periodic servicing of the boat in accordance with manufacturers' recommendations in the applicable owner's manuals.

## BOAT MODEL IDENTIFICATION

Sea Hunt Boats has a permanent record of your boat, which is identified through the "Hull Identification Number" (HIN). Data regarding equipment and accessories, as well as dealer/shipping information is documented when your new Sea Hunt is "Warranty Registered".

The "Hull Identification Number" is located on the upper starboard side of the transom. It is a significant source of identification and must be noted in all correspondence and orders.

When contacting your dealer concerning maintenance or warranties, please have all relevant information such as serial numbers (HIN) and model number available. This information is on your copy of the warranty card.

### SEA HUNT BOAT MFG. CO., INC. REGISTRATION CARD

Sold To \_\_\_\_\_

Address \_\_\_\_\_

City \_\_\_\_\_ State \_\_\_\_\_ Zip \_\_\_\_\_

Model No.	Serial No.	Date of Sale	Color

Primary Use:           Pleasure            Commercial

Dealers Name \_\_\_\_\_

Address \_\_\_\_\_

City \_\_\_\_\_ State \_\_\_\_\_ Zip \_\_\_\_\_

IMPORTANT: The Federal Boat Safety Act requires registration to be maintained on product sales. Dealers must fill out and mail registration cards immediately upon sale of product.

## REGISTRATION NUMBERS

Federal and State laws require a power boat to be registered in the state where it is primarily used. Registration numbers and validation stickers must be displayed according to regulations. The registration certificate must be on board when boating. The boat serial number, or Hull Identification Number (HIN), is required on the registration form. The HIN should be included on all documents or any correspondence to provide you with timely service.

# BOATING SAFETY

## REQUIRED SAFETY EQUIPMENT

The US Coast Guard (USCG) requires that every boat have specific equipment on board, and there may be additional local requirements. With the exception of a horn and navigation lights, these safety items are not factory supplied.

## FIRE EXTINGUISHER

At least one Type-1 hand held portable fire extinguisher must be carried on board. For boats over 26' two are required. Refer to USCG rules for accessibility requirements. Check extinguisher(s) regularly for charge status.

## PERSONAL FLOTATION DEVICE (PFD)

You must have a USCG approved personal flotation device of Type I, II, or III aboard for each passenger, in addition to one Type IV throwable PFD. **Always wear a PFD when boating.** In some states, children are required to wear a PFD at all times. Check your local regulations.

## SOUND SIGNALING DEVICES

Your Sea Hunt is equipped with an electric horn which meets the USCG requirements for a sound signal device. A small self-contained air horn or a whistle is always a good idea for a back-up in case of a power failure.

## VISUAL DISTRESS SIGNALS

USCG approved visual distress signals are required for day and night use when operating on US waters. Approved signals include flares, orange smoke, an orange distress flag, or a battery powered distress light.

## LIGHTING

Your Sea Hunt boat is equipped with navigation lights which comply with both Inland and International rules. As of this printing, the rubrail lights on the BX models are approved for inland (less than 3 miles offshore) use only.



Type I  
Life Preservers



Type II  
Buoyant Vests



Type III  
Flotation Aids



Type IV  
Throwable Devices

## ADDITIONAL RECOMMENDED EQUIPMENT

In addition to the required safety equipment, there are additional items that will provide an extra margin of safety and convenience for you and your passengers while boating.

- First aid kit and manual
- Anchor with at least 100' of rode
- Mooring lines and fenders
- Combination boathook/oar
- Non-aerosol lubricant
- Tool kit
- Spare engine fuses (refer to engine manual)
- Waterproof flashlight
- Portable AM/FM radio with weather band
- Spare batteries for radio and flashlight
- Sunglasses and sunblock
- Local charts and compass\*

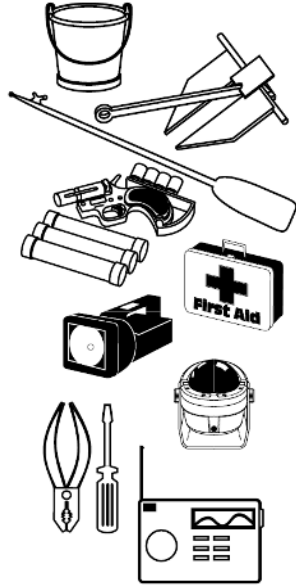

Normally, this equipment is dependent on the body of water and the length of the trip. Your dealer can assist you in selecting the appropriate equipment for your trip.

Keep tools and spare parts in good condition. Replace parts removed from spare parts kit. Most importantly use U.S. Coast Guard approved or marine certified parts where applicable. Conditions found requiring corrective action should be serviced by qualified repair personnel.

**\* Sea Hunt installs a Ritchie magnetic compass on all models. This compass needs to be calibrated to your particular boat and geographic location before it can be used as a navigation aid. Please follow the instructions in the leaflet included in your owner's packet, or use the QR code below to access the calibration instructions.**



## EMERGENCY INFORMATION

While boating, unpleasant situations may develop. Before emergencies materialize you should prepare yourself on how to cope with them, whether they happen aboard your vessel or someone else's. Prepare a plan for specific situations that may occur such as fire, man overboard or collision, to give you the confidence and ability necessary for an emergency. The key factor is to remain calm, and advance planning will greatly improve your chances of doing this.

### FIRES

A fire aboard your boat is very serious. In case of fire, you should immediately stop your boat and shut off the engine. Have everyone aboard put on their personal flotation device. If the fire is accessible, use the fire extinguisher at the base of the flames using a sweeping motion.

If the fire cannot be extinguished within a few minutes, use a distress signal and call for help on the radio. All persons should jump overboard and swim clear of the burning boat.

### SWAMPING, FLOODING, OR CAPSIZING

A boat may capsize or swamp when least expected. Like fires, try to formulate a plan in advance on what to do if it should happen. Keep in mind the following guidelines:



- Try to turn the engine OFF to prevent damage.
- Have everyone aboard put on their personal flotation device.
- If there are people in the water, try to locate them, and guide them to the safety of the hull.
- **STAY WITH THE BOAT!** All Sea Hunt Boats under 20 feet in length are designed to meet or exceed level flotation requirements. so that, if swamped, the crew may be able to bail the cockpit out and restart the engine. Larger models should keep a portion of the boat above water, depending on load and degree of damage to the hull.
- Climb up on the hull and try to signal for assistance.
- Don't try to swim to shore. It's usually farther than it looks.
- To help guard against swamping and capsizing, see that load items do not shift in the boat and do not use too much power or speed in turns.

## COLLISIONS

If you are involved in a collision with another boat or a stationary object (reef, sandbar, bridge, pier, etc.), first check all persons involved for injuries and then inspect your boat for damage. Federal law requires you to provide assistance if it will not subject you to further danger.

- If the boat is taking on water, have everyone put on their PFDs.
- Signal for help
- Attempt to plug any holes you find

## WEATHER

### STORMS

Getting caught in severe weather is hazardous. The best advice for boaters in bad weather is to **STAY HOME**. Check with local weather stations, the U.S. Coast Guard, or National Weather Service broadcasts for the latest conditions. (162.4-162.55 MHz) It is recommended to check the weather not only before but periodically while you are boating, as weather conditions can change rapidly. If a storm approaches:

- return to port or seek safe harbor immediately.
- make sure all persons aboard are wearing a PFD.
- reduce your speed and head into the wind as much as possible.

When lightning is involved, certain safety precautions should be taken. Dock the boat and seek shelter on land. If this is not possible seek refuge inside the boat until the storm has passed. Stay out of the water!

Lightning will seek a ground when it strikes and may pass through metal components if it hits your boat. Avoid contact with metal parts of the boat under these conditions.

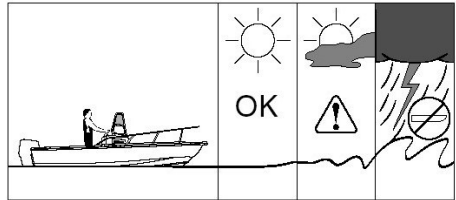

### FOG

If you encounter fog, set a course using your GPS or compass and navigational chart. Reduce your speed. Have everyone aboard act as lookouts to prevent collisions. Sound your horn intermittently to warn others of your presence. You must also listen for signals from other boaters in the area.

## EMERGENCY STOP SWITCH

Sea Hunt boats are equipped with an emergency stop switch that is supplied by the engine manufacturer. This is a safety feature that, if used properly, will shut the engine(s) down if the operator leaves or falls from the helm position.

This ignition shutdown switch includes a shut-off switch, switch clip, lanyard and lanyard clip. The lanyard clip is attached to the operator. If a situation arises where the boat should stop, a pull on the cord to release the clip from the shut-off switch will shut down the engines. To reset the emergency stop switch, simply reinstall the switch clip.

*Effective April 1, 2021, use of this device is **required** for all recreational craft less than 26 feet in length and having over a 3 horsepower motor.*

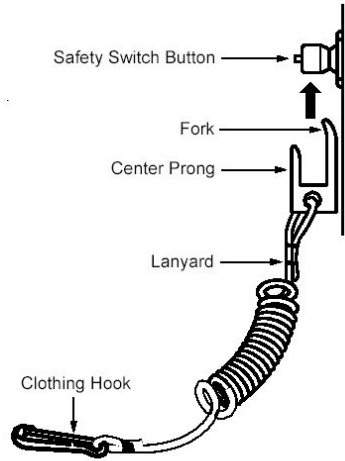

## RENDERING ASSISTANCE

The owner or operator of a vessel is required by law to provide all practical or necessary assistance to any person or vessel in distress, unless rendering aid would put his own vessel or passengers in danger.

## ACCIDENT REPORTING

Report all boating accidents to your local authorities. Federal regulations require boat operators that are involved in an accident to submit a written report within 48 hours. In the event of death or disappearance notification is required immediately by phone or radio in addition to the written report. Keep contact numbers and radio frequencies for the USCG and your local harbor patrol offices, sheriff and police stations handy at all times.

## BOATING SAFETY TIPS

Safety is the first priority in any boating trip. Remember- the safety of your vessel and all aboard are your responsibility. The following precautions will add to you and your passenger's boating safety and pleasure.

- Study all operation and maintenance manuals for your Sea Hunt before operation. Contact your dealer with any questions or concerns. Proper operation and maintenance will ensure quality performance and the longevity of your boat.

- A written float plan left with a reliable person will be valuable information if you have a mishap and do not return on time. Upon returning inform the holder of the float plan to prevent false alarms about your safety.
- Never operate (or allow anyone else to operate) your boat while under the influence of drugs or alcohol.
- Do not allow individuals under 16 years of age to operate your boat. Inexperienced drivers should not be allowed to operate the boat without constant and direct supervision.
- Instruct at least one person to pilot your boat and be familiar with basic boating techniques and safe operation in the event of an emergency.
- While boating, passengers should be settled in a safe position with arms and legs inside the boat. Handholds and rails should be used. Do not allow bow, transom or gunwale riding.
- Keep your boat speed under control. Respect for other boaters and those on shore is common courtesy. The operator of the boat is responsible for any injury or damage caused by the boat's wake. Your wake could swamp or damage a smaller craft or endanger its passengers. Stay alert for posted "No Wake Zones".
- Your Sea Hunt Boat is equipped with a boarding ladder or swim platform to aid in reboarding the boat from the water. Never attempt to use the boarding ladder while the engine is running. A shift lever in neutral could become engaged causing severe injury or death to swimmers. Do not operate your boat in swimming or diving areas at any time. **Serious injury or death WILL occur from contact with a rotating propeller!** Use extreme caution whenever swimming near the boat, even when the engine is off. A propeller will tend to rotate if subject to a current and could cause serious injury or death. Your boarding ladder is designed for use by persons boarding the boat from the water. Do not use the boarding ladder while the boat is out of the water, as damage to the boat and/or ladder could result. **Never use the motor as a ladder!**
- When venturing into unfamiliar waters, try to collect as much information on the area beforehand. Obtain charts for new areas whenever possible.
- Recommend to passengers that they wear boat shoes or tennis shoes to help prevent slipping or falling.



# BASIC RULES OF THE ROAD

Boat operation is governed by the **International Regulations for the Prevention of Collisions at Sea 1972 (72 Colregs)** and the **1980 U.S. Inland Navigation Rules (Inland Rules)**, also known as the Rules of the Road. You may also be responsible for any local regulations (rules that elaborate on minor details of the Inland Rules). The boundaries between the 72 Colregs and the Inland Rules are indicated by a dashed magenta line (demarcation lines) on your navigational charts.

For convenience, we have listed the most referenced Rules of the Road in this manual.

## MEETING HEAD-ON

Neither boat has the right-of-way in this situation. Both boats should decrease speed, should turn to the right, and pass port-to-port. However, if both boats are on the left side of a channel, each vessel should sound two short horn blasts and pass starboard to starboard.

## PRIVILEGED BOATS

Privileged boats have right-of-way and can hold course and speed. Sailboats and boats paddled or rowed have the right-of-way over motor boats. Sailboats under power are considered motor-boats. Small pleasure craft must yield to large commercial boats in narrow channels. Use common sense when applying these rules.

## BURDENED BOATS

The burdened boat is the boat that must make whatever adjustments to course and speed necessary to keep out of the way of the privileged boat.

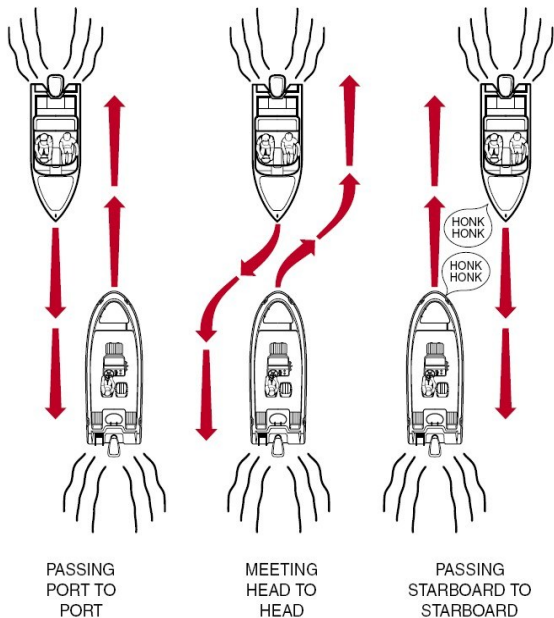

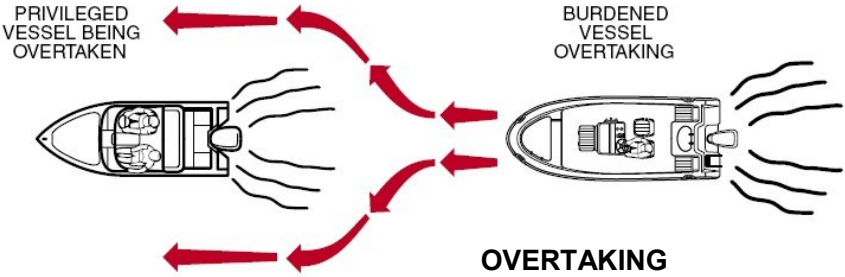

## CROSSING

In crossing situations, where two power boats meet, the boat to the right from the 12 o'clock to the 4 o'clock position has the right-of-way. It must hold course and speed. The burdened boat keeps clear and passes behind the privileged boat. Power boats going up and down river have the privilege over power boats crossing the river.

## OVERTAKING

The boat that is overtaking one ahead of it is the burdened boat and must make any adjustments necessary to keep out of the way of the privileged boat.

## THE GENERAL PRUDENTIAL RULE

The general prudential rule regarding right-of-way is that if a collision appears unavoidable, neither boat has right-of-way. As prescribed in the Rules of the Road, both boats must act to avoid collision.

## NIGHT RUNNING

Boats operating between sunset and sunrise (hours vary by state) must use navigation lights. Nighttime operation, especially during bad weather or fog can be dangerous. All Rules of Road apply at night, but it is best to slow down and stay clear of all boats, regardless of who has right-of-way. Protect your night vision by avoiding bright lights and if possible have a passenger help keep watch for other boats, water hazards, and aids to navigation.

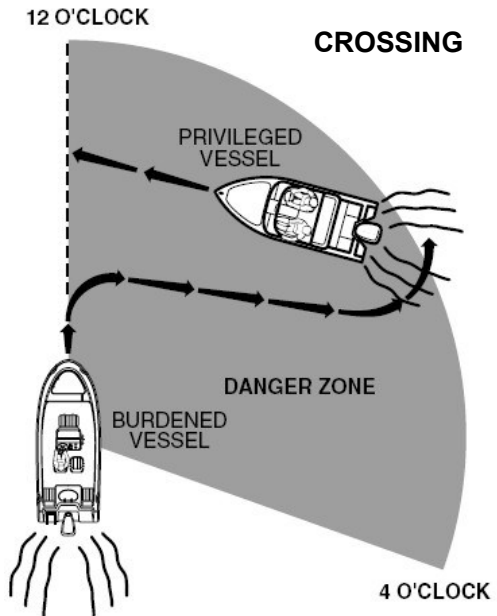

## LOADING CAPACITY

Though **overloading** is a primary cause of many boating accidents, **improper** loading is equally hazardous. Boaters should know the amount of weight on board and evenly distribute the weight within the boat. There is a capacity label affixed at the helm station of your boat if it is less than 26 feet in length. On larger boats, it is left to the captain to determine their safe load limit. Know your boat's maximum capacity and don't overload!

## CARBON MONOXIDE

Exhaust fumes contain carbon monoxide (CO), an odorless and colorless gas. Carbon monoxide is poisonous and a health hazard that can be fatal if inhaled. Symptoms of CO poisoning can include: dizziness, nausea, headache, sleepiness, vomiting, throbbing in temples, muscular twitching and the inability to think clearly. If you or anyone else experience these symptoms, immediately get away from fumes and into an area with plenty of **FRESH** air. If symptoms persist seek medical attention.

### **WARNING**

**DO NOT INHALE EXHAUST FUMES! EXHAUST FUMES CONTAIN CARBON MONOXIDE, A DANGEROUS AND POTENTIALLY LETHAL GAS.**

The boat operator should be aware that CO is a component of any boat or generator's exhaust. You are susceptible to CO while operating, mooring, and or anchoring in an area containing other boats emitting engine exhaust. An operator, likewise, needs to be aware of the consequence of his actions on other boats. Be especially aware of operation of an engine or auxiliary generator with boats moored along side each other- the exhaust can travel and accumulate in enclosed areas of other vessels.

When operating a boat- whether at cruising speeds, slow speeds, or stopped- with canvas tops, side curtains and or back curtains in place, be aware of engine exhaust to ensure that emissions do not accumulate in the boats interior (the "station wagon" effect). Maintain proper ventilation by adjusting the canvas enclosure.

## SUGGESTED BOATING CLASSES AND LITERATURE

Boats must be operated according to prescribed safety rules and traffic regulations. This manual contains basic boating tips and is not intended as a substitute for a complete review of the safety rules and regulations. We recommend you consult the following agencies for further recommendations on safe boating and instructional classes:

- United States Coast Guard ([uscgboating.org](http://uscgboating.org))
- United States Coast Guard Auxiliary ([cgaux.org](http://cgaux.org))
- United States Power Squadrons ([usps.org](http://usps.org)).

Additional boating knowledge can be obtained from some of the following:

- *Boating* magazine (Bonnier Publishing) ([boatingmag.com](http://boatingmag.com))
- *Boating Skills and Seamanship* (US Coast Guard Auxiliary) ([cgaux.org](http://cgaux.org))
- *Boatman's Handbook* by Tom Bottomley

For more information on boating safety courses in your area, contact:

- United States Power Squadrons at 1-888-367-8777
- US Coast Guard Boating Hotline at 1-800-368-5647 or your local Coast Guard Auxiliary.

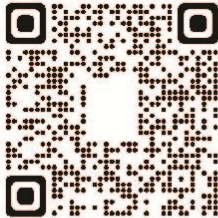

[uscgboating.org](http://uscgboating.org)



[cgaux.org](http://cgaux.org)



US Power Squadron  
YouTube channel

# GENERAL BOATING INFORMATION

## IMPORTANT INFORMATION ABOUT YOUR FUEL SYSTEM:

Beginning in 2009, the United States Environmental Protection Agency (EPA) began phasing in stricter requirements for marine fuel systems. These requirements are designed to reduce pollution from both liquid spillage and evaporative emissions from marine vessels. Your new Sea Hunt is equipped with the highest quality (USCG rated A1) low-permeation fuel lines, and either an aluminum or a three-layer low permeation plastic fuel tank.

Additionally, boats manufactured after March 16, 2012 will be equipped with additional components in the vent and fill lines, including valves in fill and vent lines and a carbon canister vent system. The valve system is designed to activate the automatic shutoff feature on the delivery nozzle at a predetermined level to ensure that the tank is not overfilled and to maintain proper venting. Occasional early shutoffs may occur—this is normal, just as when filling your car. Some high-volume fuel dispensers can cause problems as well— you may have to use the pump handle to manually reduce the rate of fill to minimize shutoffs. Always be aware of your beginning and ending fuel level— if you know you have pumped enough to be close to capacity, **DO NOT “TOP OFF”! Intentionally filling to more than rated capacity will not allow the vent system to function correctly and could introduce fuel into the carbon canister, requiring replacement of the canister.** Here are some tips to keep your system functioning as designed for a cleaner, greener boating experience:

- When fueling on a trailer, fuel with the keel approximately level with the ground. In the water, this is the natural floating attitude of your Sea Hunt— just keep it balanced side to side (You should already have everyone out of the boat when fueling as a normal precaution).
- Make sure you have the dispensing nozzle inserted fully into the boat’s fuel fill.
- Maintain control of the dispensing nozzle— don’t set the catch (if equipped) and walk away.
- Use a portable container for emergency fueling only. If you have to use a portable container or fuel caddy to fill your boat, remember the automatic shutoff will not work, and do not fill over the rated capacity.
- When trailering your boat, avoid parking on extreme slopes for an extended period of time, particularly with a full tank in hot weather.

## FUELING SAFETY

Safety during fueling requires CAUTION and COMMON SENSE.

Observe the following precautions carefully. Check with your dealer if you have questions. Check your engine manual to confirm the type of fuel and oil specified by the manufacturer. Try to avoid fuel containing alcohol (ethanol). Over time alcohol may deteriorate some rubber materials used to make up your fueling system, and can attract water into the system. If you must use fuel containing ethanol, make sure it is no more than 10% ethanol (E10), and add a quality fuel stabilizer while filling your tank. **NEVER USE FUEL WITH AN ETHANOL LEVEL OVER 10% IN YOUR BOAT!**

### • **BEFORE FUELING:**

- Correctly identify your boat's fuel fill point (yes, people still put fuel into rod holders, water tanks, etc.). If fueling in-water, position the boat so that you can stand on the dock to fuel— not in the boat.
- Have a fully charged fire extinguisher nearby.
- Observe all safety regulations for the handling of fuel.
- Extinguish all cigarettes and smoking materials.
- Shut down all engines.
- Close all ports, hatches, windows, and engine compartments to prevent fumes from accumulating in closed areas.
- Turn battery select switch(es) to the "OFF" position to insure that all lights, electronic equipment, etc. are off.

### • **DURING FUELING:**

- Keep the fuel supply nozzle in contact with the fuel tank opening to prevent any static sparks.
- Do not over fill tank. Wash and clean-up any spilled fuel. Secure the fuel cap and check fuel lines and connections for leakage.
- Properly dispose of rags or sponges used for clean-up on shore. Do not store these clean-up rags in the boat.
- After fueling open all ports, windows, and hatches to ventilate closed areas.
- Conduct a "sniff test" around the boat to make certain all fumes are vacated before using the battery select switches.

## DISCHARGE REGULATIONS

### DISCHARGE OF OIL

The Federal Water Pollution Control Act prohibits the discharge of oil or oily waste into or upon the navigable waters and contiguous zones of the United States, if such discharge causes a film, sheen upon, or discoloration of the surface of the water or causes a sludge or emulsion beneath the surface of the water. Depending on circumstances, fines can be from \$5,000 up to \$25,000. The US Coast Guard requires that any vessel 26 feet or greater in length display a placard notifying the crew and passengers of discharge restrictions. Each placard must be at least nine inches wide and four inches high, made of a durable material and printed with letters that are at least 1/8 of an inch in height.

This placard is installed on applicable models at the factory in a location of frequent access.

### DISPOSAL OF PLASTICS AND OTHER GARBAGE IN WATERS OF THE UNITED STATES

The MARPOL ANNEX V is the Act to prevent pollution from ships and other vessels. Federal and international regulations prohibit the discharge of plastic garbage anywhere in the marine environment. Plastic includes but is not limited to: synthetic fishing nets, ropes, lines, straws, six pack holders, Styrofoam cups and lids, bottles, buckets and plastic bags. These regulations also restrict the disposal of other types of garbage within specified boundaries from shore. These regulations also require a placard be displayed on boats 26 feet in length or greater, but in a readily visible location. **This placard is supplied in the owner's kit on applicable models and is to be installed by the owner in a readily visible area of their choosing.**

<b>NOTICE- DISPOSAL OF WASTE</b>	
<i>Annex V of the MARPOL treaty is an international law to provide for a cleaner, safer marine environment, making it illegal for any vessel to dump plastic trash overboard. Violations may result in penalties of up to a \$25,000 fine and imprisonment. State and local regulations may further restrict the disposal of garbage.</i>	
<b>LOCATION</b>	<b>ILLEGAL TO DUMP</b>
U.S. fresh and salt waters, inland up to 3 miles from shore	<b>Plastic</b> and Garbage (including but not limited to: paper, rags, glass, food, dunnage, linings, packing materials that float, metal, crockery)
3 to 12 miles from shore	<b>Plastic</b> , dunnage, linings, and packing materials that float, garbage not ground to less than one inch (including but not limited to: paper, rags, glass, food, metal, crockery)
12 to 25 miles from shore	<b>Plastic</b> , dunnage, linings, and packing materials that float
More than 25 miles from shore	<b>Plastic</b>

## DRIVING

Do not allow passengers to ride in the boat while trailering. Check brakes prior to leaving. Drive as steady as possible and avoid sudden jerks. Anticipate stops to make them smooth. Road trips call for occasional stops to make sure the boat and trailer are still secured properly.

## TRAILERING

The adjustment and balance of your boat on the trailer determines how easily your boat may be transported. The tongue weight on the hitch ball should be 5-10% of the total weight of your boat, motor and trailer. Tail-heavy loads cause swaying while trailering. The rollers and/or bunks of your trailer should be adjusted so that the weight is distributed evenly across the stern and forward throughout the keel sections. Your dealer is capable of adjusting your trailer properly.

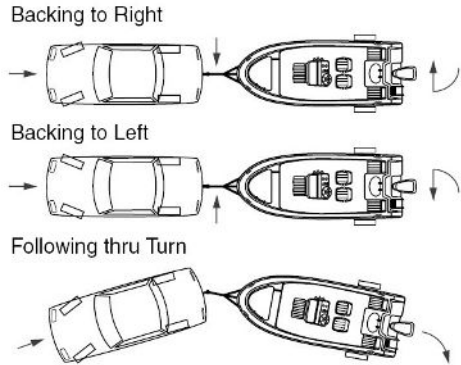

Practice maneuvering the trailer. The trailer always backs in the opposite direction of the vehicle: To maneuver the trailer, turn the steering wheel in the direction you want the trailer to go. Prior to initial launch familiarize yourself with this manual and all aspects of your boat. Below is a checklist to follow when trailering your boat:

- Consult your state laws as to brake and axle load requirements.
- Check brakes for proper operation and fluid level prior to departure on each trip.
- Check springs and undercarriage for loose parts.
- Check tires for proper inflation. Under-inflated tires heat up rapidly and tire damage or failure is likely to occur.
- Check wheel bearings for grease and tighten lug nuts before each trip.
- Your boat should be fastened to the trailer by a line from the bow eye to the winch line PLUS a bow tie-down to the winch stand or trailer tongue. The stern of your boat should be tied down to the trailer from the stern eyes.
- Check to be sure the tail lights and turning signals work prior to towing.
- Bimini tops and canvas curtains are not designed to stay on boats at highway speeds. Before towing, take down Bimini tops and any canvas, if so equipped.

- Carry a spare tire for both your trailer and your towing vehicle along with sufficient tools to change them.
- Be sure all lids, doors, and the engine cowling are latched securely before trailering.
- Stow any loose cushions.
- On extended trips, carry spare wheel bearings, seals, and races.
- While traveling, check the wheel hubs every time you stop for gas or refreshments. If the hub feels abnormally hot, the bearing should be inspected before continuing your trip.
- When rounding turns on highways or streets, do not cut corners.
- Go slowly over railroad tracks.
- Before backing your trailer into water, disconnect the light plug from the towing vehicle to reduce the likelihood of blowing out lights when they become submerged.

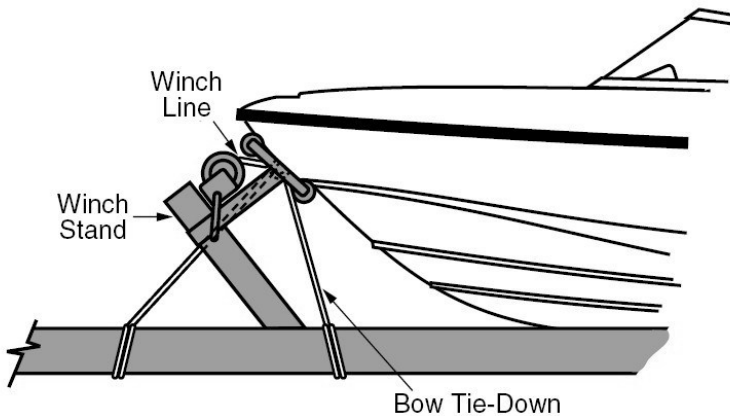
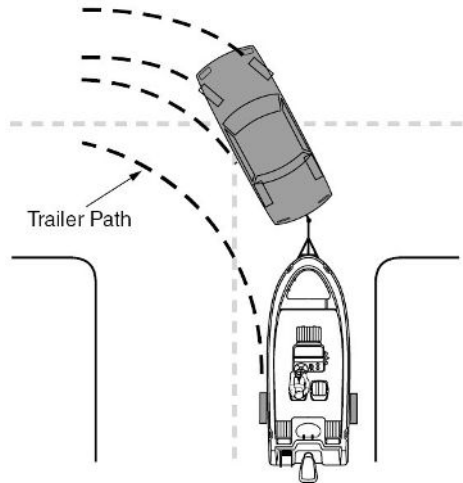

## PRE-START CHECKLIST

The following checks are essential to safe boating and must be performed before starting the engine. Get in the habit of performing these checks in the same order each time so that it becomes routine.

- Check that all required maintenance has been performed.
- Check the weather conditions.
- Check that the required safety equipment is on board and in good condition.
- Check that the fire extinguisher is fully charged, and be sure that you are familiar with its proper use.
- Check that no fuel, oil or water is leaking.
- Check all hoses and connections for leakage and damage.
- Check that the hull drain plug is in place and securely tightened before putting your boat in the water.
- Check that battery terminals are clean and tight.
- Check that all navigation lights operate properly.
- Check that fuel and oil levels are adequate. Always carry more fuel than you anticipate using, in case you are forced to change your plans for weather or other reasons.
- Check that throttle/shift control is in neutral.
- Check that the steering system operates properly.

## LEAVING / APPROACHING THE DOCK

Unlike an automobile, the stern of your boat reacts first when turning. A turn to the right will swing the stern to the left and vice-versa. Remember that turning your boat away from an object such as a dock will tend to swing the stern toward that object.

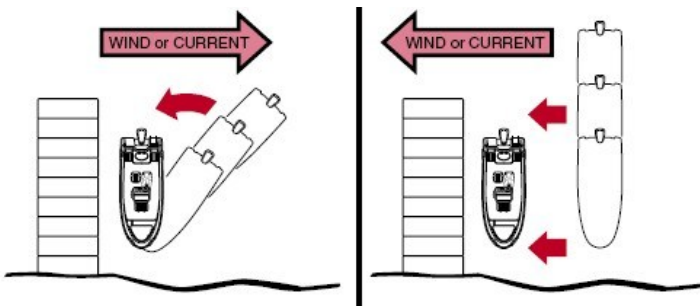

## TOWING OR BEING TOWED

In the event of a mishap or power loss you may need to tow a boat or have yours towed. Remember you should not tow a boat larger than your own. Never tow a boat if you are not equipped with the proper lines— nylon ropes are recommended, as they have the strength and elasticity needed to absorb the shock of towing and sudden jerks. A person should never hold a towline- always secure it to the boat.

Before towing a boat, make a bridle and tie it securely to the stern eyes on the transom with enough slack to clear the engine(s). Pad the line wherever it comes into contact with the boat to prevent chafing. Attach a tow line to the bridle so that it can slide from side to side to prevent too much pressure on a single stern eye. The tow line should then be attached to the bow eye or to a bridle on the towed boat. The tow line should be a minimum of twice the length of the towing boat, the longer the better. When passing the tow line to the other boat do not try to run in too close. Send either a light line or attach the towline to a life preserver to be pulled in. Beware of each boat's propeller. The towed boat should always have someone at the

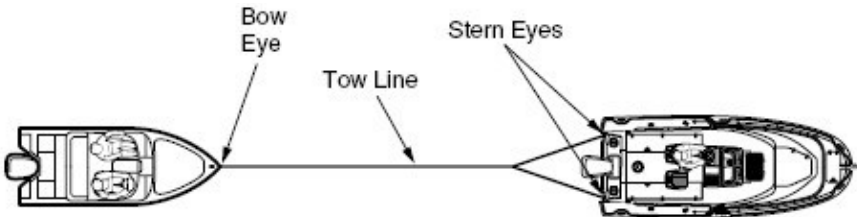

wheel since the boat may swing off course. Start the tow off slowly. A steady pull at a moderate speed should be used. It is important to keep the slack out of the propeller area. Watch the action of the towing boat. If excessive slack develops in the towline and contact is obvious turn in either direction to avoid hitting the stern. As a precaution passengers on both boats should stay clear of the tow line. Lines under stress could snap and fly in any direction, causing injury.

## SHALLOW WATER

Most boats that become grounded can be floated off with motors tilted to reduce the draft at the transom. Do not attempt to power off if the propellers are in mud or sand due to possible damage to your engine's cooling system. With motors tilted, try rocking the boat from side to side to break the suction of mud from the keel. Move passengers or heavy objects away from the point where the boat is grounded. Do not lower or start the engines until the boat is clear of the bottom. When boating in water with tidal changes be mindful of fluctuations of the water level.

If you are grounded on an incoming tide you can wait until the tide is high enough to re-float your boat. However, if the tide is outgoing you will need to take quick action to avoid getting stuck. If this is not possible then set an anchor to keep the boat from being driven further aground. Place the anchor to counter the action of the wind or current. In some cases, the anchor can also be used to pull the boat free.

Many inland areas have rocks and stumps which could crack or puncture a fiberglass hull. Be familiar with the area and use caution in shallow water.

## NOTICE

It is illegal to tie your boat to navigational aids such as buoys and markers

### ANCHORING

Some factors that determine the size and type of anchor most suitable for your boat include the size of your boat and the type of lake, sea or river bottom in your boating area. Pay out enough rode to equal 4-6 times the depth you are anchoring in. Never anchor solely off the stern of the boat, especially in strong winds or currents. The weight of the stern and the flat surface of the transom facing the waves can easily cause water to enter over the transom and swamp the boat.

### USING A WINDLASS

Anchoring can be less laborious if your boat is equipped with a windlass. Sea Hunt installs a 12 volt windlass and a stainless steel anchor roller as standard equipment on the Ultra models 245 through 305, and all Gamefish models. The windlass may be operated either by foot switches mounted at the bow or from a rocker switch in the panel at the helm. Take the time to familiarize yourself with proper operation and the limitations of a windlass system. **Due to the deep-V design of the hull and forward position of the rope locker, it may be necessary to check the incoming rode to ensure it is not piling up under the windlass, and redistribute the rope or chain in the locker as needed to ensure smooth operation of the system.** See the windlass operation and service manual included in your owner's package for further details. **Always drive the boat to the anchor for retrieval- never use the windlass to pull or tow the boat, or for any other purpose than anchor deployment and retrieval.**

## WARNING

WINDLASS IS TO ASSIST IN ANCHORING ONLY.  
ANY OTHER USE MAY RESULT IN INJURY OR  
PROPERTY DAMAGE.

## GENERAL INFORMATION ON BOAT HANDLING

The best method of learning how to handle and obtain optimum performance from your boat is to practice and experiment. After break-in you should experiment with the throttle settings to determine the most comfortable and economical range for your particular loading conditions. We suggest that you make a speed/RPM chart in order to obtain the most economical operation. Operate the boat at various speeds and check the fuel consumption. Determine the amount of operating time remaining when the fuel gauge drops into the low fuel level. Make a log of this type of information and have it available when using your boat. Other statistics you may want to determine could include the following:

- Minimum speed for effective steering.
- Turning radius at different speeds.
- Response to steering at low speeds.
- Control of the boat using the engine(s) in close quarters.
- Time and distance to bring the boat to a stop at different speeds.
- Acceleration and deceleration rates.

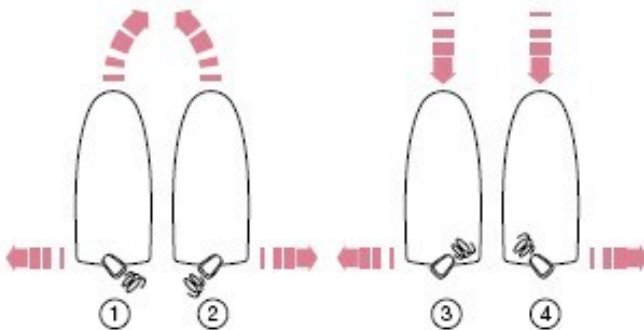

- ① **RIGHT TURN**  
Turn wheel to right and accelerate - Stern will move to left.
- ② **LEFT TURN**  
Turn wheel to left and accelerate - Stern will move to right.
- ③ **BACKING TO PORT**  
Turn wheel to left and accelerate in reverse - Stern will pull to left.
- ④ **BACKING TO STARBOARD**  
Turn wheel to right and accelerate in reverse - Stern will pull to right.

## COMMON NAUTICAL TERMS

**Abeam** - Perpendicular to a boat's keel, side-to-side

**Access (Inspection) Plate** - A removable, watertight cover that provides quick access to enclosed areas for maintenance or visual inspection.

**Aft** - Toward the rear or stern of a boat.

**Beam** - The greatest width of a boat.

**Bilge** - The lower interior compartment(s) of the hull.

**Bow** - The forward/front part of a boat.

**Bow Eye** - A U-shaped hull fitting used to attach the trailer winch to the boat.

**Bulkhead** - Vertical partition between compartments inside the hull.

**Chine** - Outer bottom edge of the hull; the junction of the side of the boat and the bottom.

**Cleat** - Deck fitting with arms or horns on which lines are fastened.

**Deck** - Upper structure which covers the hull.

**Draft** - Depth of water required to float the boat (excluding motors)

**Freeboard** - Distance from the topside of the gunwale to the waterline of the hull.

**Gunwale (or Gunnel)** - Top outer periphery of the deck

**Hatch** - An opening in the deck.

**Head** - A toilet or toilet area in a boat.

**Headroom** - Vertical distance between the deck and cabin or canopy top.

**Hull** - The lower outer "shell" of the boat.

**Keel** - The lowest external portion of the hull; the junction of the two sides of the bottom.

**Knot** - Unit of speed in nautical miles per hour.

**Lee** - The side that is sheltered from the wind.

**List** - To tilt or lean to one side.

**Port** - The left side of the boat when facing the bow.

**Scupper** - Holes permitting water to drain overboard the boat.

**Sheer** - Curve or sweep of the deck as viewed from the side; the joint between the deck and hull

**Starboard** - The right side of the boat when facing the bow.

**Stern** - The rear end of a boat.

**Stern eye** - A U-shaped hull fitting used to secure the stern of the boat to the trailer.

**Stringer** - Longitudinal members in the hull that provide structural strength.

**Transom** - The flat area across the aft end of the hull.

**Wake** - The waves made in the water by a moving boat.

# PERFORMANCE

## PERFORMANCE FACTORS

Maximum performance is dependent on many factors and cannot be guaranteed. These factors will vary with changing conditions. Some of these factors are listed below.

## ENGINE EFFICIENCY

Engines operate most efficiently at the RPM confirmed in the engine operating manual and performance reports for your boat. Efficiency will decrease if normal care and maintenance are not performed— if neglected power will drop and speed will decrease. In addition, expensive repairs may become necessary. Be sure to follow all instructions in the engine operation manuals.



## WEATHER CONDITIONS

Weather conditions affect engine performance. Barometric pressure and humidity both influence horsepower. A change of weather could cause a 10% loss in horsepower on some hot days.

## LOAD DISTRIBUTION

A decrease in performance will be noticed when gear, equipment, passengers and fuel are added. This type of extra load will affect the performance of the boat according to the distribution of the weight. Water accumulation in the bilge will also affect performance. Keep the bilge dry to eliminate this problem.

## MARINE GROWTH

Maximum performance is obtained only when your hull bottom is clean. Marine growth on the bottom of the boat will increase resistance and decrease speed. These conditions will also increase fuel consumption.

## TRIM AND TILT

Your outboard(s) are equipped with power tilt and trim mechanisms. The purpose of power tilt function is to raise the engine for launching, loading or trailering your boat. The power trim function may be used to adjust the boats planing performance and running attitude. Trim refers both to the weight distribution inside the boat and to the angle of thrust of the drive unit. The angle of thrust of the drive unit forces the bow up or down. The proper trim angle will vary depending on the load and weight distribution in your boat. If the drive is raised too far, you could cause the propeller to "ventilate", resulting in a sudden increase in engine RPM and a loss of speed. If this occurs, immediately reduce engine speed and lower the drive until the condition is corrected.

## PROPELLER

The propeller (“prop”) converts the engine’s power into thrust to propel the boat. The right prop for any boat in a specific application is one that allows the engine to turn up to its full rated RPM, but no more. It is necessary for the engine to turn to full rated rpm in order to develop full rated power. If the boat is used for more than one type of activity (both fishing and water skiing for example), the prop can only be optimized for one situation. Since a spare prop is an excellent safety item, the purchase of a second propeller which is more efficient for another application is not necessarily just “added expense”.

### ⚠ CAUTION ⚠

Stay within the engine manufacturer’s maximum and minimum RPM ranges when replacing props. This information is located in your engine manuals. If your boat does not have a tachometer consult your dealer for propeller changes.

## PROPELLER TERMS

Propellers are identified by two numbers (for example 14 x 17), and by material (typically either aluminum or stainless

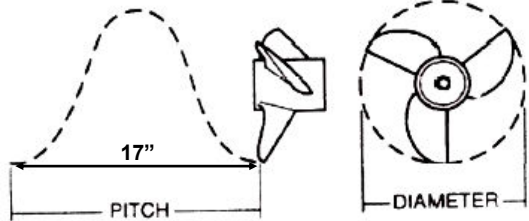

steel). The first number in the size is the diameter and the second is the pitch. The diameter is the distance across the circle swept by the extreme tips of the propeller blades. The term pitch comes from the old screw analogy used to approximate propeller action. This analogy says that a propeller screws itself through the water much as a wood screw works itself into soft pine. The pitch is therefore the angle of the blades expressed in the theoretical distance a propeller would travel in one full revolution— in this example, 17”. In reality, the propeller actually pushes the boat forward less distance than its pitch. The difference between the pitch and the actual distance traveled is called “slip”.

## OUTBOARD PROPULSION SYSTEM

The engine manufacturer supplies all vital information concerning your engines in the operation and maintenance manuals. Details of important engine maintenance schedules, lubrication system, cooling system and engine alert systems are outlined in these manuals. Your familiarization with this engine reference material will result in the proper usage and service that is essential for safe and enduring engine performance. These manuals are included with the owner’s packet.

## **⚠ WARNING ⚠**

**DO NOT INHALE EXHAUST FUMES! EXHAUST CONTAINS CARBON MONOXIDE, A DANGEROUS GAS WHICH IS POTENTIALLY LETHAL.**

### **ENGINE SYSTEMS**

Do not attempt to service any engine or drive component without being totally familiar with the safe and proper service procedures. Certain moving parts are exposed and can be dangerous.

### **ENGINE WARRANTY**

A warranty registration card is included with all engine manuals and should be completed and returned to the engine manufacturer as soon as possible. **The engine warranty is separate from your boat warranty and must be handled through the engine manufacturer.**

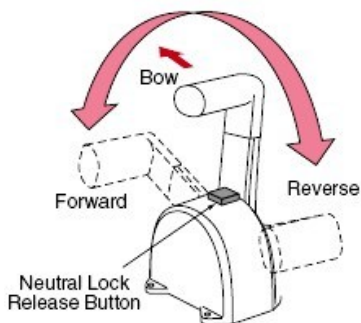

**Binnacle Mount Control**

### **THROTTLE/SHIFT CONTROL**

Your new Sea Hunt uses a binnacle (top mount) combined throttle/shift control located at the helm station. Newer models and advanced steering systems will add functions to the control—take the time to familiarize yourself with all that it can do.

### **NEUTRAL SAFETY**

Your Yamaha powered Sea Hunt contains a neutral safety switch which prevents the engine from being started in gear. When starting your engine the control lever must be placed in the neutral/middle position. When functioning properly, this mechanism does not allow the engine to start when the control is not in the neutral position.

### **SHIFT FUNCTION**

After your engine is started simply move the control lever in to the forward detent position. To place the engine into reverse move the control lever backwards to the reverse detent location. Remember that propellers are designed for maximum forward thrust so reverse thrust will not be as efficient.

### **THROTTLE FUNCTION**

**Forward Throttle:** To engage the throttle mechanism while in forward gear position continue to move the lever forward past the detent in a controlled motion. This motion will begin to increase engine RPM which will cause the boat to move forward.

**Reverse Throttle:** To engage the throttle mechanism in reverse continue to move the lever forward (back or aft) past the detent in a controlled motion. This motion will begin to increase engine RPM which will cause the boat to move backwards.

**Neutral Throttle:** To engage the neutral throttle function on your Yamaha control box depress the neutral lockout button located at the center of the control lever's pivot point. While fully depressing the button inward move the control forward or reverse to activate the throttle.

 **CAUTION** 

Failure to fully depress the neutral throttle before moving the control lever may result in the control lever engaging the gear shift mechanism. Thus resulting in the propeller being engaged and causing the boat to lunge in the direction the lever was moved.

### STOPPING / BRAKING

To stop a boat that is moving forward you may reverse the shift mechanism. This reversal of prop rotation will provide a "braking" action, slowing the boat.

 **CAUTION** 

Abrupt BRAKING ACTION, with the boat moving too fast, may cause a wake that can rise above the transom and potentially flood the boat. ALLOW ENGINE RPM TO **DECREASE** BEFORE SHIFTING INTO REVERSE.

### CONTROL CABLES

If your throttle or shift cables need replacing use the same style and length as the original equipment.

### STEERING

Your new Sea Hunt will be equipped with either hybrid electric/hydraulic or fully electric steering. Both systems greatly reduce the effort required to maneuver the boat, and the electric systems will even be adjustable for effort and number of turns. Both systems require regular inspection of moving parts. Refer to the appropriate manual included in your owner's packet for more information.

## **TRIM TABS**

Sea Hunt Boats installs Bennett trim tabs. The tab planes mounted on the transom of the boat are actuated by electric rams, controlled by switches at the helm. The switches are labeled "bow up-bow down" and correspond to the side of the boat the switch is closest to, although the tab on the opposite side of the boat causes this motion. Always remember to fully retract the trim tabs prior to putting the boat on a trailer. Do not use the trim tabs as a step- this may cause damage to the unit or result in personal injury. See your Bennett owner's manual for complete maintenance information.

## **ENGINE LUBRICATION- 4-STROKE ENGINES**

Your Yamaha 4-stroke engine is equipped with an engine oil system similar to an automobile. Sea Hunt factory rigged engines have been filled with the correct amount and type of oil upon installation. The owner should check the oil condition and level after the first few hours of operation, and follow a routine oil change schedule as recommended in your engine manual.

# DISPLAYS AND SWITCHES



All factory rigged Sea Hunt boats are equipped with Yamaha digital displays for propulsion system monitoring. Since Yamaha may improve or add features to their product, we have included this section as an overview of most of the terminology and functions for safe operation of your new boat. You will need to consult your Yamaha display manuals included in your owner's kit for complete instructions on setup and operation of your particular system. Not all features listed are available on all systems.

## TACHOMETER

The tachometer indicates the engine RPM. Consult your engine owner's manual for the recommended operating RPM range. If your engine(s) do not reach the maximum RPM recommended, a change in propeller may be necessary.

## SPEEDOMETER

The speedometer indicates your boat speed, and can display speed in two units of measurement: MPH (miles per hour), or knots ( 1 Knot = 1 nautical mph, or 1.15 statute mph).

## FUEL GAUGE

The fuel gauge indicates the fuel level. When checking fuel level, be aware that the attitude of your boat in the water can impact the reading. Where possible, the fuel gauge is set up at Sea Hunt; however a more accurate reading can usually be obtained by following a setup procedure during the first filling of the tank. Consult your dealer and Yamaha manual for instructions.

**USABLE FUEL LEVEL-** The fuel pickup tube inside the gas tank is not capable of withdrawing all of the fuel from the tank. For this reason, never operate your boat at extremely low fuel levels.

## **VOLTMETER**

The voltmeter indicates the battery charge with the engines off and the charging system output with the engine running. A reading of 12-13 volts with the engines off is normal, indicating a fully-charged battery. Readings below 11 indicate a weak battery which may not start an engine. A reading of 13-14 volts when the engine is running is normal. Readings over 14 volts may indicate regulator problems. Low or fluctuating readings may indicate loose connections or trouble in the regulator and alternator circuit.

## **TRIM GAUGE**

The Trim Gauge displays the degree of tilt/trim of the outboard engine. In general a boat is started from a stationary position with the engine trimmed in. The engines are “tucked in” to the transom and will tend to keep the bow down as the boat comes on plane. As speed is increased and running angle reduced, the engines are gradually trimmed out to maintain a desirable running angle. Keeping the engines trimmed too far in will cause the boat to plow water and possibly “bow steer”, veering unexpectedly.

## **WARNING SYSTEMS**

Yamaha outboards have several warning systems, with an audible alarm located under the dash. There may also be an alert on the display in addition to the audible alarm. The purpose of the alarm is to alert the driver to potentially damaging engine operating conditions. Consult your engine owner’s manual for exact location and function of these systems. Yamaha engine warning systems also incorporate an RPM reduction mode that effectively controls the engine RPM to a maximum of 2500 when a the warning system is activated. Consult your authorized dealer if your engine is not achieving proper operating RPM.

## **OVERHEAT WARNING INDICATOR**

This feature indicates when the temperature of the cooling water circulating through the engine is too high. When the temperature exceeds the recommended operating range indicated by your engine owner’s manual, immediately shut off your engine to prevent damage. Overheating is often caused by obstruction of your engine’s intake on the lower unit. Check the intake strainer first if you experience trouble.

## **LOW FUEL WARNING INDICATOR**

This feature indicates when the fuel level in the main fuel tank is becoming low.

## SWITCH PANEL

At the helm station you will find an accessory switch panel. These accessory switches are specified below.

## BILGE PUMP(S)

This two-way switch serves as an overriding manual switch in the event of failure of the automatic switch on the pump.

## COCKPIT LIGHTS

The cockpit lights provide illumination for the cockpit area.

## HORN

The horn is sounded by pressing the momentary switch on the panel. It should be used to warn or alert other boats or persons.

## LIVEWELL(S)

These activate the livewell pump(s). Ensure that the valve under the pump is in the open position before activating the pump. Most models also have a flow control on the aerator fitting in the livewell—use this to adjust fill and circulation rates. **If your well is equipped with a recirculation pump, close the filling aerator head after filling the well to keep water from draining back through the filling pump.**

## WASHDOWN/FRESHWATER/MISTER

These switches pressurize the applicable water system—raw or fresh (if equipped).

## NAVIGATION / ANCHOR LIGHTS

The three position switch (NAV-OFF-ANCHOR) changes the lighting configuration to running or anchor lights, and also operates the gauge lights. Select the NAV position when running at night (running lights). This will illuminate the red/green running light(s) forward and the white all around light aft. Select the ANC position while anchored at night. The ANC position will illuminate only the white all around light. Be sure to stow folding tops or canvas at night if they would obstruct other boats' ability to see the all around light.

## ACCESSORY

Switches labeled "ACC" are provided for the addition of non-factory installed accessories. Always make sure the fuse or breaker is adequate for the accessory being installed.

## CIRCUIT BREAKERS

Circuit breakers are located on the panel beside the switch they protect on BX models and the Ultra 219 through 245. Larger Ultras and all Gamefish have a separate breaker panel located inside the console below the battery switch panel. If a breaker trips repeatedly, troubleshoot and repair the circuit before using the boat. Wiring diagrams for several current Sea Hunt models are included in this manual. Contact the Sea Hunt factory if your wiring diagram is not included.

# MAINTENANCE & SERVICE

## GENERAL

The amount of maintenance required to keep your boat operating properly and to maintain the appearance is dependent on how the boat is used, amount of usage, type of water, climate, etc.

Your hull and deck are constructed by the hand lay-up method using the highest quality fiberglass mat and knitted and woven fabrics. This method of construction ensures a proper fiberglass-to-resin ratio and uniform thickness, which together result in boat of superior strength. This process ensures that your Sea Hunt boat is the strongest, most durable fiberglass boat possible.

The bilge areas should be kept clean and dry. Leaks found early and corrected are less likely to cause damage. Do not allow grease and dirt to build up.

Proper maintenance of your boat is not only a source of pride, it is the key to maintaining your boat's value. A few simple steps will keep your fiberglass Sea Hunt looking showroom bright for years.

## EXTERIOR FIBERGLASS FINISH

The exterior finish of your Sea Hunt is a thin layer of pigmented resin called gelcoat. Its purpose is to protect the inner laminate from moisture and chemicals and to give the parts the glossy smooth colored finish that is the hallmark of fiberglass boats. Although gelcoat has a hard smooth surface it does contain microscopic pores that will allow surface discoloration if not kept clean.

## MAINTENANCE

Normal exterior finish maintenance of your Sea Hunt boat is similar to the care you would give your automobile. Do not use caustic, highly alkaline cleaners or those containing ammonia or chlorine. These cleaning agents may darken gelcoat, and chlorine based cleaners can cause stainless fixtures to rust. The resulting stain is a chemical reaction and can be removed with a rubbing compound followed by waxing.

## CLEANING

The best way to prevent discoloration and soil build-up is to hose the boat with fresh water after each outing or on a regular basis. This build-up is the result of use and environmental pollutants. Clean the boat regularly with a mild household detergent and plenty of fresh water. Use a sponge on smooth surfaces including the deck and a brush on the nonskid. Rinse away all grime and residue.

## WAXING

Gelcoat can lose its gloss due to constant exposure to the natural environment and pollutants. It will require special attention to restore

the original gloss and color. See a local dealer for advice on wax for your boating region. The wax film will seal the pores as well as enhance the looks of your boat. **DO NOT** wax non-skid surfaces, they will become slippery. While waxing your boat inspect the surface for any damage. Have the damage corrected as soon as possible.

Gelcoat will naturally dull with age. Factors that will affect the rate of discoloration are: the sun, pollution, old wax accumulation and the salt content of water. Most discoloration is shallow in depth—polishing compound (fine abrasive) or rubbing compound (coarse abrasive) is recommended for use on fiberglass finishes to remove scratches, stains or restore severely weathered surfaces. These products can be applied by hand or mechanical means. The process below will help restore fiberglass finishes:

- Clean the affected area with a good detergent.
- Remove stubborn stains or discoloration by gently wet sanding the affected areas with 600 grit “wet or dry” sandpaper. **ALWAYS SAND IN ALTERNATING DIRECTIONS.** Use plenty of water and sand curves using the same method. Dry the area to make sure all the discoloration has been removed. Repeat this process if necessary.
- Buff using a polishing compound suitable for fiberglass, an electric buffer (1750- 1800 RPM) and an 8-inch lamb’s wool pad.

### **CAUTION**

- Keep buffer moving. Do not allow it to rest in one spot.
- Heat build up will quickly distort the surface.
- Compounding too often or excessive compounding can wear away the gelcoat.
- When buffing is complete wash away compound with clear, clean water and dry the area.
- Once the area is clean it may be waxed. This will enhance the gloss while providing a seal to retard staining or soil accumulation.

## **REPAIRING**

Though gelcoat is a very durable material, it is susceptible to scratches, blistering and web-like cracks (crazing) over time. It is elastic enough, however, to withstand strong blows while flexing with the hull’s movement. Gelcoat problems are cosmetic and will not

affect the structural integrity of your boat. Some gelcoat damage and imperfections, such as nicks and scratches can be repaired by obtaining a color match patch kit. This kit can be purchased through your Sea Hunt dealer— instructions are included in the patch kit. Acetone is recommended for prep and cleanup of gelcoat repairs.

**⚠ CAUTION ⚠**

**M.E.K. (Methyl ethyl ketone peroxide), gelcoat and acetone are flammable and hazardous chemicals that must be handled properly. Follow instructions carefully. After the gelcoat is catalyzed it will heat up and emit fumes. When finished with catalyzed chemicals or if they start to build up heat, submerge completely in water until cool.**

### **BOTTOM PAINT**

If you routinely leave your boat in the water for more than a few days at a time, the hull bottom (below the waterline) should be painted with anti-fouling paint to protect it from marine growth and barnacles that hinder performance. Since some anti-fouling paint slowly dissolves to prevent marine growth, it is advisable to inspect and clean the boat bottom at least once per season. Repaint when necessary. To help prevent blistering use an epoxy barrier coat applied in conjunction with the anti-fouling paint.

**⚠ CAUTION ⚠**

**Do not paint the outboard motors with anti-fouling paints designed for boat hulls. Many of these paints can cause severe damage to the engines.**

### **CANVAS**

Although your Sea Hunt's canvas is made using the highest quality fabric and latest sewing techniques, it will not be completely leak proof in all conditions. Over time, the material and the seam holes in your canvas may stretch and leak, but this can be minimized by observing proper care and storage techniques. Please understand that Sea Hunt does not warrant the fit and design of the canvas to be entirely watertight under all conditions.

### **CANVAS CARE**

To maintain your boat's top and other canvas in top condition, the fabric should be cleaned regularly to prevent soil build-up from becoming embedded. Simply brush off any loose debris, hose down the canvas,

and clean with a mild soap solution and warm water. Do not use petroleum or ammonia based cleaners on canvas or clear vinyl, they will cause yellowing. For heavily soiled fabric on tops, you may want to remove the top from the frame and lay it flat for cleaning.

Water repellent was applied to your canvas during manufacturing. After several cleanings some of the repellent may have been released and retreatment of the fabric is recommended. A product such as the ones made by 303® (goldeagle.com) expressly for cleaning and retreatment of canvas materials will greatly enhance the look and life of your canvas pieces.

When cleaning marine fabrics, it is important to observe the following:

- Always use a mild soap— never use detergent.
- Water should be cold to lukewarm (never more than 100° F).
- Air dry only. Never apply heat to marine fabrics. If you are cleaning the material while still on the boat, follow these simple steps:
  - Brush off excessive loose dirt.
  - Hose down the material to remove any remaining loose residue.
  - Apply cleaning solution.
  - Allow cleaner to “work” for a few minutes.
  - Use a soft bristle brush to clean.
  - Rinse thoroughly.
  - Air dry.

If stubborn stains persist, refer to the Sunbrella website ([www.sunbrella.com](http://www.sunbrella.com)) for help with your particular type of stain. Always remember to protect the other surfaces in your boat (vinyl, stainless steel, etc.) from cleaning agents that may not be compatible.

Fabrics should be retreated with 303® Fabric Guard™ after thorough cleaning or after five years of use. Be sure to follow the product directions exactly for best results.

**Sunbrella® is a registered trademark of Glen Raven, Inc. 303® is a registered trademark of Gold Eagle Manufacturing.**

## **ZIPPERS & SNAPS**

Zippers and snaps will loosen with use. Use care when starting the zipper to prevent damage. Lubricate the snap buttons and zippers with petroleum jelly or paraffin, and always grasp the canvas as close to the button as possible when unsnapping from the boat.

## CLEAR VINYL

Clean clear vinyl thoroughly with denatured alcohol and then apply a protective layer of clear wax. Do not use paste wax – it will turn the vinyl yellow. This process should be repeated as necessary to maintain the protective wax coating.

## STORAGE

Observe the following steps when putting your folding canvas top option in the stored position:

- Dry all canvas thoroughly before stowing to prevent mold and mildew.
- Fold the top and zip it into the canvas cover provided.
- Pivot the covered top into a safe, stowed position.
- Store and secure all other canvas before trailering.

## CAUTION

Secure the folded top when in the stowed position to prevent damage or the loss of the canvas.

Remove the top, front and side panels; roll them up for storage. For long-term storage of clear vinyl pieces, place a sheet of heavy tissue paper on both sides of the piece before rolling it up. This will keep the vinyl from getting stuck to itself and help protect it from scratches. Roll loosely into about a 6"-8" diameter tube— do not roll too tightly. **Never fold the clear vinyl pieces!**



## **UPHOLSTERY**

Your exterior vinyl upholstery may be cleaned with a mild solution of household detergent and fresh water. Commercial cleaners for vinyl also work well. Since the seams of your exterior upholstery are not waterproof, your upholstery should be stored in a dry location or covered when not in use.

## **HARDWARE MOUNTING**

When mounting hardware to boat surfaces, first check for any wiring, hoses, etc. behind the surface before doing any drilling or cutting. Also check that the surface is adequately reinforced for the hardware you wish to install, and add backing materials if needed. Finally, make sure all penetrations are sealed properly with a marine grade sealant to prevent leakage of water into the hull.

## **CAULKING/GASKET**

Deck fittings, bow rails, windows, hatches etc., have been caulked or gasketed with the highest quality material to ensure a waterproof joint with the boat. However, the working action of normal use will tend to flex the joint and eventually break down the seal. Periodically inspect the caulking or gaskets for leaks. Re-caulk or replace the gaskets when necessary or have your dealer do the repairs.

## **STAINLESS STEEL RAILS & HARDWARE**

Your hardware is made of grade 316 stainless steel, and needs regular cleaning to maintain its "less staining" properties. The key to maintaining stainless steel is to keep it clean with a mild solution of soap and fresh water. Remove salt or dirt from your stainless steel on a regular basis, and never use chlorine-based cleaners on stainless steel..

## **ACRYLIC AND PLEXIGLASS**

Your new Sea Hunt may have a windscreen, dash accent piece, console door, or livewell lid made from acrylic or plexiglass. Clean these materials with a mild soap (no detergents or abrasive cleaners) and a clean, soft cloth (never use paper towels). If the material does get damaged, there are commercially available compounds that can remove some minor scratching or swirling but results may vary with the degree of damage and the experience of the person performing the work. Care should also be exercised when cutting or drilling into these materials so as to prevent unwanted cracking or chipping.

## **GLASS**

Newer models in the Gamefish series, the Ultra series from the 239 on up, and the BX 25 FS will have a tempered safety glass enclosure as standard equipment on the hardtop frame. Care for this with regular glass cleaners and a clean soft cloth or clean paper towels.

## CORROSION AND RUST

As previously mentioned, Sea Hunt does everything possible to ensure the hardware on your new boat is installed so as to minimize the chance of corrosion. However, the metal components on your boat do require regular maintenance to keep them looking new.

There are two types of corrosion that can affect the metal fixtures on a boat—oxidation (rust) and electrolytic corrosion. Contrary to popular belief, stainless steel is not rust-*proof*—it is more rust-*resistant* than other types of steel, but it will still rust if not properly cared for. Avoid cleaners that contain chlorides or chlorites (such as bleach) because they will attack the microscopic layer on the surface of the steel, allowing oxygen in and starting the rusting process. Regular rinsing with fresh water and application of one of the commercially available corrosion inhibiting products will greatly increase the beauty and life of your stainless steel hardware.

Electrolytic corrosion occurs on metal parts below the waterline. It can be identified by a pitted, rough surface with a (usually) white, powdery residue when dry. This is caused by stray electrical currents in the water around your boat, which can be from a number of sources. Some electrolytic corrosion is normal— but the electrical system in your new Sea Hunt is designed to minimize the potential paths for current to flow, and susceptible parts like the outboard motor and electric trim tabs are provided with sacrificial anodes by their manufacturers. These anodes are designed to corrode in order to protect the metal components they are attached to, and they require regular inspection and periodic replacement to ensure they keep protecting your boat. The rate of replacement is dependent on a number of factors— the pH and salt content of the water the boat is in, and the condition of the electrical systems on nearby boats and the dock if the boat is stored in a slip at a marina are the biggest factors. Anodes also require different materials depending on the main water type the boat is used in— fresh, brackish, or salt. Boats with both DC and AC systems, whether from a generator or shore power, are much more susceptible to current leakage than a regular 12 volt system alone. If you think you're having higher than normal levels of electrolytic corrosion, ask your dockmaster if there have been any other complaints, and if the marina is checked by a marine electrician on a regular basis. Check for boats around yours that are plugged into shore power, and ask to test around them as well— especially older boats. Excessive corrosion could also be a sign of a more dangerous problem— people have become immobilized and have drowned while swimming in an area with an AC current leak close by.

## **ANODIZED ALUMINUM COMPONENTS- LEANING POSTS, ROD HOLDERS, T-TOP FRAMES**

Due to the nature of anodized aluminum and the harsh exposure conditions of the marine environment, it is important to follow a regular maintenance procedure. Failure to follow a preventative maintenance procedure will most likely result in aluminum pitting. These parts must be washed periodically with a very mild soap and water solution. Sea Hunt recommends washing with a mild soap or a cleaner specifically formulated for aluminum. Clean after each use and every two to three weeks if stored in an outside marine environment. Strong cleaners and soaps must not be used; never use abrasive cleaners or products that contain chlorine bleach. These products can remove the anodized coating. Pay special attention to the upper tubes of a hardtop or T-top frame. The area just below the top is shielded by the canvas or fiberglass top and does not receive the natural rinse that rainwater provides. Failure to thoroughly clean and maintain this area will allow contaminants that attack the anodized aluminum to remain on the frame.

For maximum protection coat parts with a non-abrasive metal protector. The best protectors will displace moisture, remove contaminants, and leave a wax film protecting the anodized aluminum. Follow the application guidelines for the product you choose.

## **SCUPPERS**

Sea Hunt boats have self-bailing cockpits. This means water on the cockpit floor drains by gravity through large aft scuppers and NOT into the bilge. The aft drains or scuppers have an external flap assembly which restricts the flow of water back into the boat. Inspect the flaps periodically to make sure that they are free of debris. The scupper flaps may need periodic replacement if the rubber becomes damaged or no longer seals properly in the thru-hull.

## **FUEL SYSTEM MAINTENANCE**

To determine whether a fuel flow problem is in your fuel system or your engine, follow this simple method. Connect a six-gallon portable tank to the engine and operate the engine. If the problem persists the likely cause is with the engine itself. If the problem goes away, the source must be in the boat's fuel system. One component that should be inspected if a restriction occurs is the anti-siphon valve. If fuel does not flow properly through this part it must be cleaned and/or replaced. DO NOT remove the anti-siphon valve and replace it with a regular barb.

**Avoid using fuels containing alcohol whenever possible.** Alcohol, particularly ethanol, will absorb water that makes fuel more corrosive to metals in tanks and carburetors. It also shortens the durability of elastomers such as hose and gaskets. Before fueling, inspect the fuel hoses, connections, and tanks for tightness, signs of leaks, and deterioration.

Annually conduct a more detailed inspection of fuel system components, especially those hidden from routine inspection. Replace any fittings, deteriorated hoses, clamps or connections immediately.

## **FUEL TANK COMPARTMENT**

The fuel compartments need to be rinsed periodically, especially when used in a salt-water environment. Dirt accumulation attracts salt that creates salt crystals. Salt crystals can corrode most metal surfaces if left untreated over a period of time. To help protect your fuel tank from rust and corrosion rinse the compartment with FRESH water. Remove the access plates from fuel tank lids and inspect this area for leaks or unsecured lines.

The access plates on your fuel compartment lid seal this area. Over time the opening and closing of these plates cause the O-rings to wear-out. Replace these O-rings as necessary to maintain the watertight integrity of the plates.

## **BATTERIES**

The batteries in your boat have been selected to match the starting requirements of your engine(s). They should be secured in a non-metallic tray to contain any electrolyte spills and an insulated boot should cover at least the positive battery terminals.

### **CAUTION**

A battery contains sulfuric acid. Avoid contact with skin, eyes or clothing.

Antidote:

- **EXTERNAL:** Flush with water.
- **INTERNAL:** Drink large quantities of water or milk. Follow with milk of magnesia, a beaten egg or vegetable oil. Contact a physician immediately.
- **EYES:** Flush constantly with water and get prompt medical attention.

**SHIELD EYES WHEN WORKING NEAR BATTERIES.**

Batteries produce explosive gases. Keep sparks, flame and cigarettes away. Ventilate when charging or using in an enclosed space.

**KEEP OUT OF REACH OF CHILDREN**

Most newer batteries are of the sealed or gel type. If you do have a battery with removable caps, fluid levels should be checked at least once a month. Fill the battery to the upper level with distilled water.

**Never overfill the battery.** Clean the terminals on all batteries by first turning off any battery switches, then by removing the terminal connections and scrubbing them with a small wire brush and a little bit of baking soda and water (being careful to keep the mixture out of the battery). Wipe dry, then reattach the cables, starting with the highest current draw conductor (i.e. starter cable) closest to the battery, and finish with a light coat of grease over the exposed metal to help keep out moisture. Follow this same procedure for winterizing, and check and charge the batteries periodically when in storage.

## **CAUTION**

Never disconnect the batteries when the engines are running. This can cause damage to the charging system. When replacing your battery, reference your engine owner's manual for recommended battery type and required performance specifications.

### **BATTERY SWITCH**

Your Sea Hunt may be equipped with a multiple battery system, with a selector switch located either near the batteries or inside the console. The purpose of a dual battery system is to provide a backup source of power in the event the main battery should become discharged. It is NOT recommended to operate the boat with the switch in the "BOTH" or "ALL" position— this could lead to discharge of both batteries. Instead, alternate operation between the two at approximately equal intervals (for example, every 10-15 hours of operation). This will ensure that both batteries will remain fully charged. **NEVER TURN SWITCH "OFF" WITH THE ENGINE RUNNING!** Refer to pages 54-56 for more information on operation and connections.

**NOTE—** The automatic bilge pump float switch is wired directly to battery 1. In the event of total discharge of battery 1, the float switch would be inoperable and will not provide protection against water accumulating in the bilge while the boat is unattended.

# WINTERIZATION AND STORAGE

## GENERAL INFORMATION

Boats stored during the winter or for an extended period of time require some routine maintenance. Prior to and during the storage process the boat and its systems should be checked for maintenance and repairs. It is recommended that you arrange these repairs during the storage period. Avoid costly damage and delay when launching your boat by having it stored and winterized properly. This information is presented as a general guide and the actual storage should be performed by a professional and authorized Sea Hunt dealership.

## BOAT STORAGE

To avoid personal injury and property damage it is advised to take extra precautions when lifting or moving the boat for storage. Sea Hunt boats are equipped with stern lifting eyes and a bow towing eye. These eyes are provided for moving and temporary lifting. For permanent lifting, you will need to have or add a bow lifting ring option. Eyes should be inspected regularly to insure structural integrity.

### **THE BOAT SHOULD NOT BE STORED BY HANGING USING THE FACTORY BOW AND STERN EYES.**

While transporting a boat by sling lift or fork lift the structure should remain as close to ground level as possible. If slings are necessary for lifting or transporting they should be in proper condition and tied together to prevent any movement (separating or slipping) which could cause damage to the boat. If tow motors are used to move the boat the forks should be padded and in a secure location under the hull near the chine. The forks should be long enough to prevent the boat from rocking forward and aft causing it to become unbalanced. Other conditions that should be considered before hauling, transporting or storing your boat include overhead lines, ground conditions (frozen or soft) and storm conditions that may arise. When storing your boat on the trailer raise and block the trailer axle to prevent tire deterioration. This is an excellent time to lubricate and pack the wheel bearings per the manufacturer's instructions.

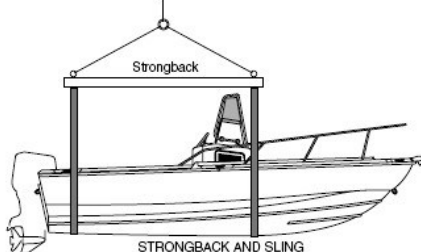
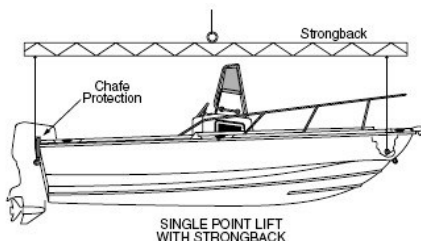

## **WINTERIZATION AND STORAGE**

Make sure the keel, chine and transom are fully supported. Indoor storage is beneficial particularly if your climate produces freezing weather. The storage unit should not be airtight but should be ventilated. Ventilation is extremely important both around and through the boat.

For outdoor storage a canvas cover should be used to prevent "sweating". One method is to build a frame over the boat to support the canvas. It should be a few inches wider than the boat so the canvas will clear the rails and allow passage of air.

The cover should be fastened securely so that winds cannot remove it or cause it to chafe the boat. A poor covering job will eventually cost more than the price of a well-made cover.

**IF THE BOAT IS SHRINK WRAPPED WITH PLASTIC DURING STORAGE, THE FUEL FILL AND VENT FITTING(S) MUST REMAIN EXPOSED TO PREVENT THE TRAPPING AND ACCUMULATION OF DANGEROUS FUMES OR SPILLAGE FROM THERMAL EXPANSION.**

## **CLEANING AND LUBRICATING THE BOAT**

Clean and wax the boat before storage. If your boat stays in the water there may be a layer of growth on the bottom. As it dries, this debris will harden. Clean, scrub, and scrape the bottom promptly when the boat is removed from the water.

Thoroughly remove all marine growth and other foreign matter from the hull. Clean the inside of hull openings, thru hull fittings and scupper drains. Inspect the hull bottom for damage.

Check cleats and rails for corrosion and tightness. Clean all stainless steel as directed under the MAINTENANCE section in this manual. Use a good quality metal protectant on all metal surfaces to prevent salt water damage. Check all hinges for corrosion. Lubricate hinges as necessary. Check for loose silicone, hinges, and un-seated gaskets. Replace or tighten where necessary.

**NOTE-** Over time, the normal flexing of the fiberglass from regular operation can result in leaks in your windows, doors and hatches. Inspect for fastener tightness and seal integrity at regular intervals.

## **DRAINING AND WATER SYSTEMS**

Remove the garboard drain plug and open all valves and sea-cocks to keep the bilge dry. Store your boat with the bow elevated for drainage.

Drain all water tanks, lines and pumps to prevent freeze damage. The fresh water system may be drained by running any faucet until the tank is empty. When empty, turn the faucet off to prevent pump damage. Residual water will not damage the tank. If desired, the fresh water system may have a non-toxic antifreeze added. This antifreeze can be purchased at marine or camping dealerships.

To drain other lines, close seacocks and run the pumps until the lines are empty. After emptying the lines, re-open the seacocks. In warmer climates draining will help prevent water stagnation.

## FUEL SYSTEM

Fill your fuel tank with fuel to minimize space in the tank for condensation to form. Add a good quality fuel stabilizer, following the manufacturer's directions on the container. **DO NOT fill your tank with fuel containing ethanol for storage!** The ethanol will absorb water and separate out of the fuel over time, resulting in a layer of water and ethanol at the bottom of your tank.

## BATTERIES

Check the electrolyte level in your batteries and fully charge the batteries before storing. A weak battery loses its charge more rapidly than a strong battery. Ideally, you should disconnect the batteries and cover the terminals with grease to prevent corrosion.

When replacing batteries in the boat remove excess grease from terminals and charge as necessary before reinstalling.

## ENGINES

Check your engine owner's manual regarding the procedures for winterizing the engines. Follow these important instructions carefully, and your engines should survive most weather conditions. Change all filters. Check hoses and clamps. If you have had any vibrations during the season look for loose engine bolts, bent shafts or bent propellers.

## STORAGE CHECKLIST

In addition to the winterization guidelines, use the following checklist as a guide for storing your boat. Additional details should be added as needed for your personal application.

- Remove all loose items and personal effects.
- Remove any detachable and valuable equipment such as electronics. Store electronics inside in a dry and secure place.
- A built-in compass should be covered. Ultraviolet rays from the sun will "cloud" the compass and make it difficult to read.
- All equipment should be winterized as directed in the manufacturer's manuals.
- Winterize engine
- Winterize fuel system
- Winterize Raw / Fresh water systems.
- Inspect & Lubricate trailer bearings and other points recommended by the trailer manufacturer.

- Store cushions and canvas indoors in a dry place to prevent mildew.
- Clean the exterior and interior of the boat
- Remove all grease, oil, salt spray etc.
- Remove all garbage. Clean the cabinets, lockers / storage, and fish boxes and live wells.
- The lids and doors should be propped open for ventilation
- Empty toilet / head and flush with fresh water
- Lubricate all hinges, valves, the backs of electrical panels and other surfaces that may rust.
- Check underwater items. Hardware should be in good condition and tight. Inspect electrical systems and have any repairs performed.

### **COMMISSIONING YOUR BOAT AFTER STORAGE**

We want you to enjoy your boating experience and it is important that you properly re-commission your Sea Hunt boat. Before placing your boat in the water for the boating season, have the hull bottom cleaned. Sand and reapply antifouling bottom paint, if necessary. Leave as much equipment and personal effects off the boat as possible until after launch and final check.

### **PRIOR TO LAUNCHING**

It is recommended that your Sea Hunt boat be re-commissioned by an authorized dealer. Below is a list of items to check and perform prior to placing your boat in the water. The following list will give you some ideas and suggestions.

- Check all gear and replace if necessary.
- Check thru hull fittings for cleanliness, damage and tightness.
- Check prop installation and tightness.
- Clean battery terminal posts with a wire brush or bronze wool. Install batteries, attach cables and tighten. Apply grease to post to exclude air and acid. Check all wire connections for contact corrosion and tightness.
- Check hull valves for easy operation and for condition of hose.
- Check operation of bilge pumps in manual and automatic modes.
- Check operation of all electrical circuits.

- Check the hose and lines on the fresh water system, install drain plug and close drain valves.
- Perform maintenance on engines according to the manufacturer's manuals prior to returning them to service.
- Fill fuel tank and thoroughly check out fuel system including lines, fittings, connections, and filters for leaks.
- Check operation of toilet (reference manufacturer's manual).
- Check all engine and steering control cables and linkage for operation. Lubricate cables and linkage as necessary.
- Fill fresh water system and check for leaks.
- Check safety equipment including flares, fire extinguisher and first aid kits. Replace items as necessary.

## LAUNCHING

Upon placing the boat in the water and before releasing the boat from the trailer or lift:

- Inspect the boat for all sources of possible leaks from bow to stern (including bilge area).
- Verify all engine and steering controls are operating correctly. If either of these critical items are not functioning as they should, **DO NOT LAUNCH THE BOAT!** Remove the boat from the water and immediately contact your authorized Sea Hunt dealer to schedule a thorough inspection and service.
- Only after you have confirmed all boat systems are operating satisfactorily should you release the boat from its mooring.
- Enjoy another great season of family fun and fishing!

# BOAT SYSTEMS

## WATER SYSTEMS

All Sea Hunt boats are equipped with a raw water system, and depending on the model and options, you may also have a freshwater system, as well as an onboard head (toilet) and plumbing for waste removal. System identification can be made easily by comparing the hose used to the photo below. The sanitation hoses are white, raw water and drain hoses will be black, freshwater will be a 5/8" dia. clear hose with braided reinforcement, and the mister system (if equipped) will have black 1/4" dia. hard tubing.

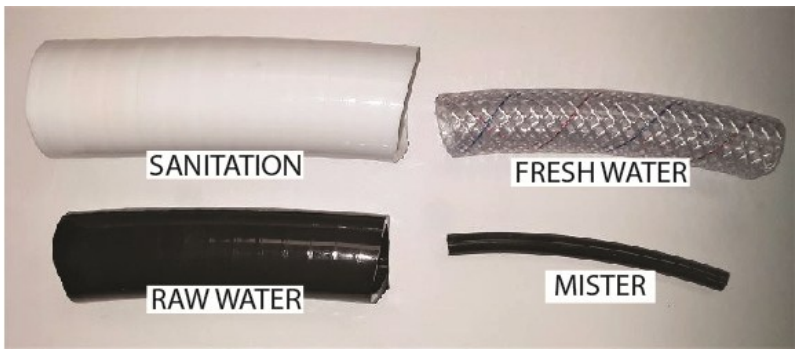

### RAW WATER SYSTEM

The raw water system serves two functions— maintain water levels in livewells and baitwells, and provide a moderate pressure source for rinsing loose dirt and debris from the deck.

### FRESH WATER SYSTEM

The fresh water system also has multiple functions. It supplies fresh water to a sprayer located in the boat, a sink on some models, and water for any factory installed permanent head (toilet) system. The freshwater tank also feeds a separate pump for the T-top mister system (if equipped).

Both raw and freshwater pumps have built-in demand switches— the dash switch can be left on and the pump will only operate if one of the accessories is utilized.

**PLEASE NOTE THAT THE FRESHWATER SYSTEM IS NOT POTABLE – DO NOT CONSUME WATER FROM THE SYSTEM!**

## HEAD SYSTEMS

In 1972 (amended 1987) Congress enacted the Clean Water Act. This law addresses a wide spectrum of water pollution problems, including marine sewage from boats in navigable U.S. waters. The law provides for “no discharge” by boats operated within three miles of shore, in enclosed lakes and reservoirs or in rivers not capable of interstate navigation. States may also have other waters declared “no discharge” if they deem in necessary. Therefore any boat toilet must be an operable, Coast Guard approved Marine Sanitation Device (MSD). These are designed to either hold sewage for pump out ashore, overboard discharge beyond the three mile limit, or to treat the sewage to Federal standards prior to discharge. Check with your local authorities or Coast Guard for any rules which apply to the area where you do your boating.

**In order to comply with the Clean Water Act, the discharge sea-cock must be kept closed and access restricted when operating the boat in a no-discharge zone. Failure to follow these rules may lead to a citation if boarded by the Coast Guard or other law enforcement agency.**

All systems use fresh water only for flush and fill. The “Fresh Water” pump switch on the helm panel must be on in order to use the head system, and adequate water level must be maintained in the freshwater tank.

The 245 and all 25 and 27 foot models (Gamefish and Ultra) are equipped with a compact gravity flush toilet with an integral holding tank. This system uses fresh water also, so the freshwater pump must be on to flush the system. Refer to the toilet manufacturer’s owner’s manual for specific operation instructions.

The electric toilet used in the 28 and 30 foot models (Gamefish and Ultra) utilizes a separate holding tank- again, refer to the toilet manual for specific instructions.

With either system, the toilet manufacturer’s instructions are included in your owner’s package– be sure to read and understand the recommended operation and maintenance procedures in the manual and abide by all laws and regulations for waste disposal. **Remember– discharge valves must be closed and access to the toilet restricted when in a no-discharge zone. This can be done by locking the console door or placing a plastic cable tie around the valve handle. Discharge can also only be performed by operating the macerator pump from the helm, further reducing the chance of accidental discharge.**

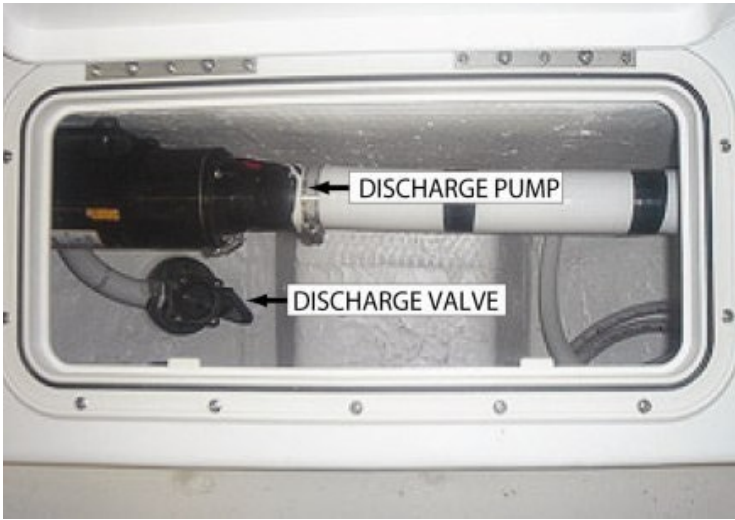

**24/25/27 toilet pump and valve layout (varies by model)**

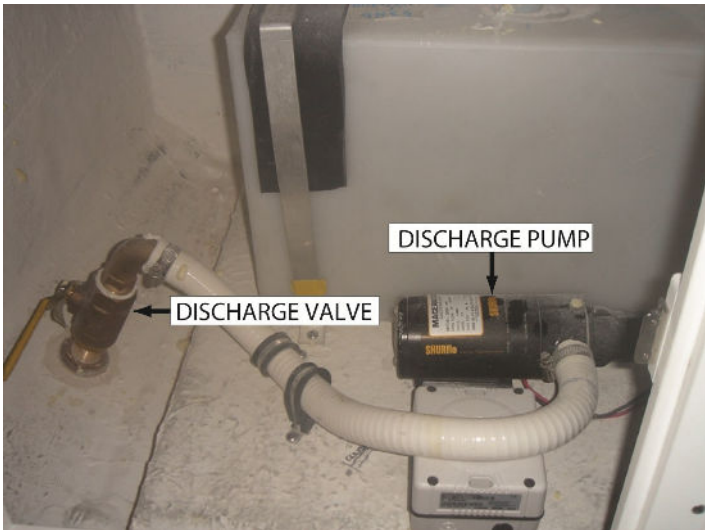

**28/30 toilet pump and valve layout**

## ELECTRICAL SYSTEM

Your Sea Hunt has a 12 volt DC system designed to provide years of service, with waterproof connectors and tinned wire used throughout for maximum corrosion resistance. Even with top quality components, though, regular inspection and maintenance is required to maximize the service life of anything exposed to the marine environment, whether fresh or salt water. A simple visual inspection of connectors and a light coating of anti-corrosion spray at least once a season will go a long way to keeping your electrical system trouble-free.

Your boat will have one of two basic systems. For the Ultra 219 through 245 and the BX models, the system is powered by two (dealer installed) batteries located under the starboard rear seat, controlled by a battery switch mounted in the same compartment. This switch is used to select between the two batteries or to combine them if needed in an emergency. If your boat is equipped with a 150 or 200 HP motor, you will need to alternate battery usage to ensure both stay charged. If your motor is 250 HP or greater, an isolator lead is installed to keep the second battery charged at all times. Keep in mind neither configuration uses a “house” battery—they simply have two sources of power in case one goes out. Circuit protection devices for the accessory harness, automatic bilge pump power, windlass (Ultra 245) and isolator circuit (if applicable) are located at the battery switch as shown (may vary slightly by model). All other accessory breakers are located beside their respective switches on the dash panel.

### ULTRA 219-245 AND BX BATTERY SWITCH

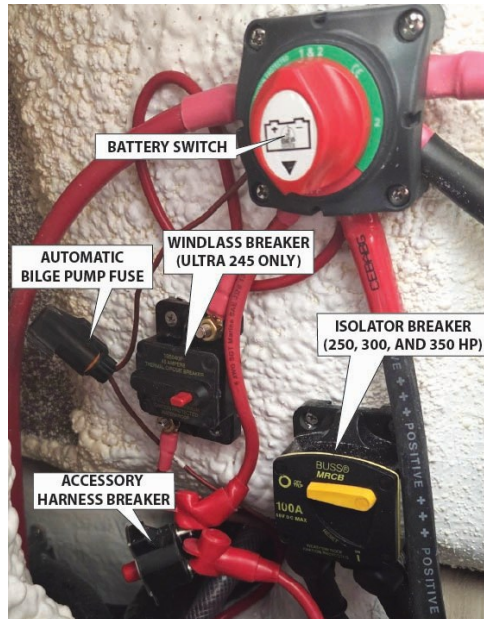

For the Ultra 255–305 and all Gamefish models, the battery switches are located on a panel just inside the console door. This panel includes the engine and house bank battery switches, breakers for the automatic bilge pumps, trim tabs, and main power breakers for the helm (switch) panel and T-top. The breakers for the individual accessories are on the panel above the battery switch panel.

These battery switches are the dual circuit type and function differently from a simple selector switch. When the engine and house switches are in the “on” position, each engine is connected to its respective starting battery and the accessories are connected to the house battery. When the engine switch is in the “combine” position, the starting batteries are connected in parallel and both engines are connected to both batteries. **Use this position ONLY when encountering a difficult starting situation.** When the house battery switch is in the “combine” position, it is connected to both the house battery bank and the starboard engine starting battery. In normal operation, run both the engine switch and the house switch in the “on” position. It should not be necessary to switch between batteries to maintain a charge unless a problem developed in one motor’s charging system. On factory-rigged boats, the house battery is charged by Yamaha’s battery isolator circuit on the port motor, so manipulation of the switches to keep all batteries charged is not necessary except in emergency situations.



**ULTRA 255-305 AND  
GAMEFISH BATTERY  
SWITCH AND BREAKER  
PANELS**



## ELECTRICAL DIAGRAMS

Information in the following section is given for reference and assistance in troubleshooting. Since Sea Hunt Boats strives to constantly improve all areas of construction, some revisions or equipment may exist that are not noted on the diagram. Consult the factory if you have questions about specific circuits that are not shown.

All wiring conforms to ABYC standards for size, temperature rating and color codes. Always use marine rated components when performing any work on your Sea Hunt's electrical system, and ensure all circuits have appropriate overcurrent protection. Sea Hunt Boats always recommends using a qualified marine electrician for any repairs or additions to your boat's system.

### BATTERY WIRING ULTRA 255\*-305 AND GAMEFISH SEE PAGE 55 FOR SWITCH FUNCTION

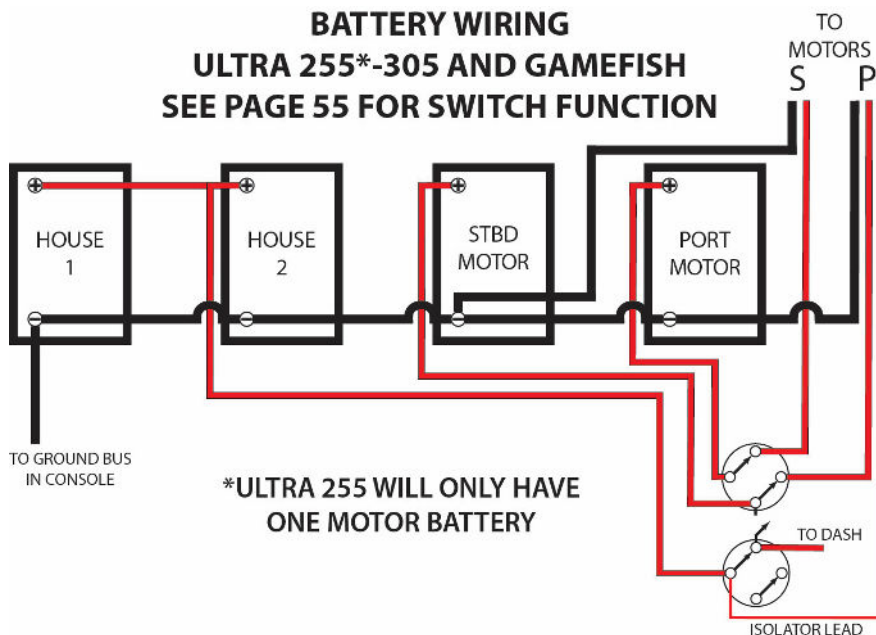





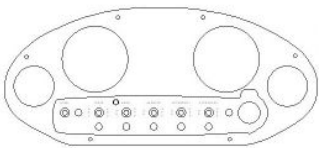

## ESCAPE SERIES PANEL

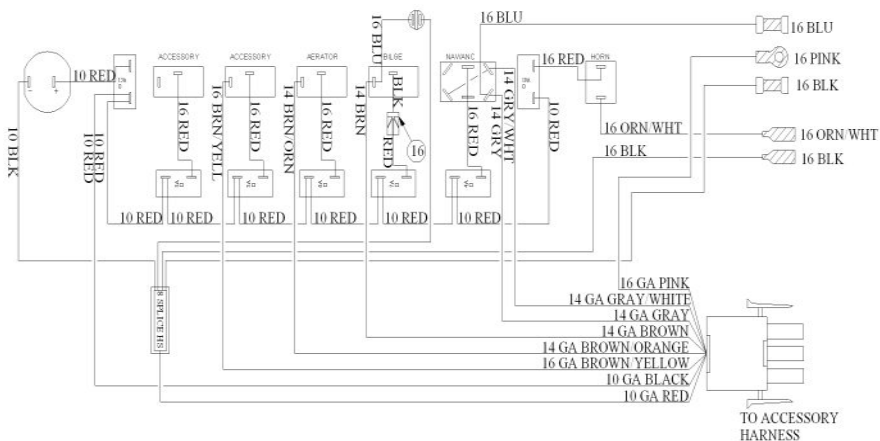

## ESCAPE SERIES WIRING HARNESS

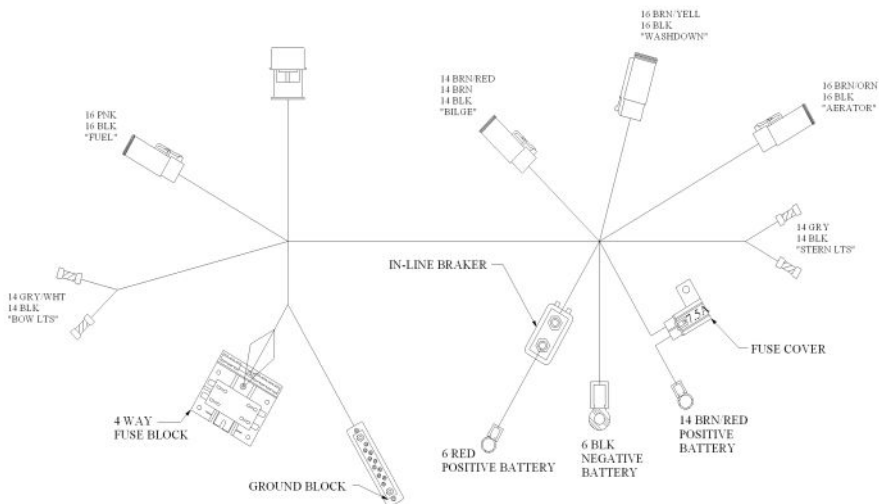









## TROLLING MOTOR WIRING

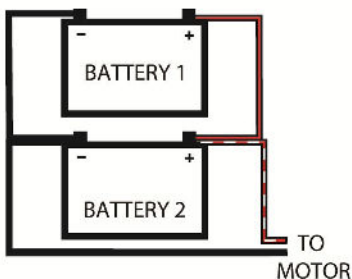

2 BATTERIES- 12 VOLT MOTOR

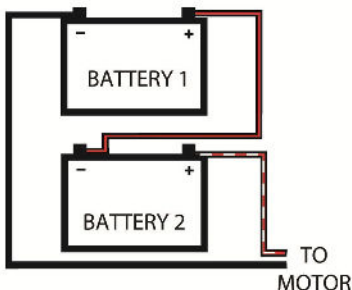

2 BATTERIES- 24 VOLT MOTOR

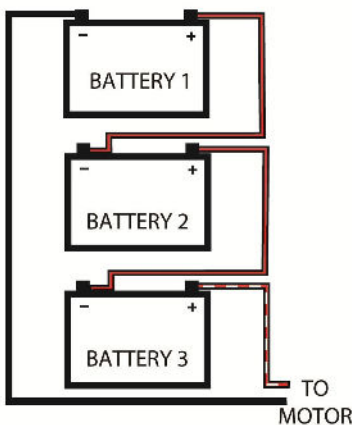

3 BATTERIES- 36 VOLT MOTOR

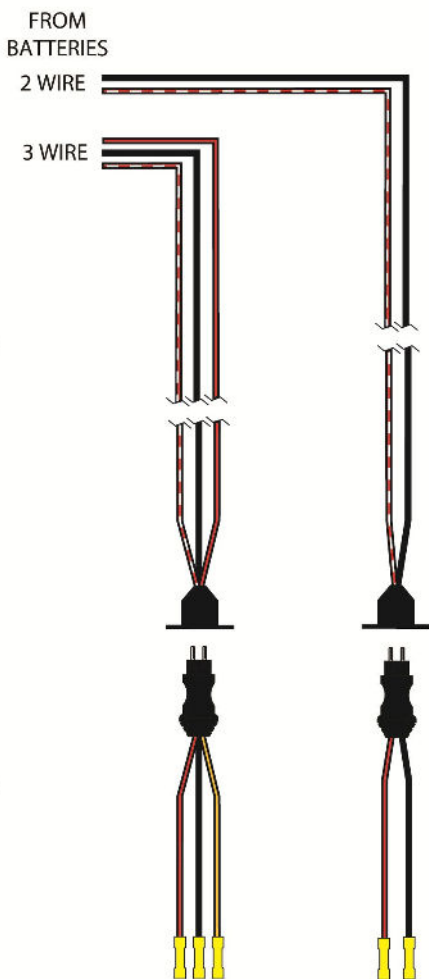

NOTE: 3 WIRE HARNESS IS TO ACCOMMODATE OLDER 12/24 VOLT MOTORS- REFER TO MOTOR MANUAL FOR CORRECT WIRING. ALL OTHERS USE ONLY BLACK (NEGATIVE) AND EITHER RED OR RED/WHITE (POSITIVE). OBSERVE COLOR CHANGE TO POSITIVE WIRES AT PLUG- RED/WHITE IN HARNESS IS RED ON PLUG (2 AND 3 WIRE)- RED IN HARNESS IS ORANGE ON PLUG (3 WIRE ONLY). INSULATE AND TIE UP ANY UNUSED WIRES.

# SAFETY LABELS

**BOW FILLER WARNING  
(IF EQUIPPED- LABEL  
IS ON FILLER SECTION)**

**WARNING**

DO NOT STAND OR SIT ON BOW FILLER UNLESS BRACKETS ARE SEATED IN THEIR RECESSES AND BOTH LIDS ARE CLOSED AND SECURELY LATCHED. FAILURE TO DO SO COULD RESULT IN PERSONAL INJURY OR PROPERTY DAMAGE.

**FUEL SYSTEM WARNING**

**WARNING**

AVOID SERIOUS INJURY OR DEATH FROM FIRE OR EXPLOSION RESULTING FROM LEAKING FUEL. INSPECT SYSTEM FOR LEAKS AT LEAST ONCE A YEAR.

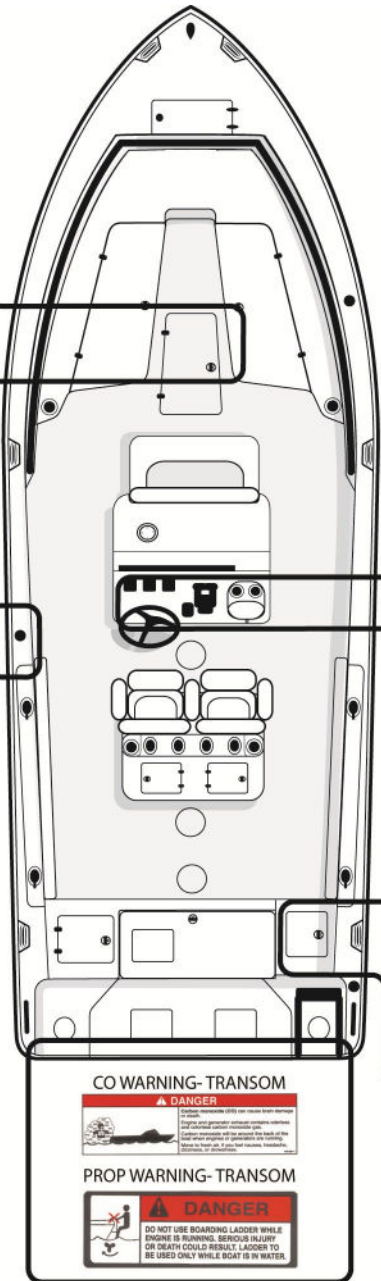

**CAPACITY LABEL  
(MODEL SPECIFIC)  
MAXIMUM CAPACITIES**

**8 PERSONS OR 1200 LBS.**

2100 LBS. PERSONS, MOTOR, GEAR.  
250 H.P. MOTOR

THIS BOAT COMPLIES WITH U.S. COAST GUARD SAFETY STANDARDS AS EVIDENT ON THE BOAT'S CERTIFICATE

MANUFACTURER: SEA HUNT BOAT MFG. COMPANY COLUMBIA, SC 29901  
MODEL: \_\_\_\_\_

PLEASE COMPLIANCE WITH NMEA REQUIREMENTS IS VERIFIED MANUFACTURER RESPONSIBLE FOR PRODUCTION CONTROL

**NMEA  
CERTIFIED**  
www.nema.org/nema-certified  
NATIONAL MARINE MANUFACTURERS ASSOCIATION

**PROP WARNING- HELM**

**WARNING**

ROTATING PROPELLER MAY CAUSE SERIOUS INJURY OR DEATH. SHUT OFF ENGINE WHEN NEAR PERSONS IN THE WATER

**CO WARNING- HELM**

**WARNING**

Certain models (200 and above) have designed a push button and generator voltage control system and may have carbon monoxide gas (CO) detector installed. Always follow the manufacturer's instructions. Do not shut off if a person shows signs of carbon monoxide poisoning. See Dealer's Manual for information regarding carbon monoxide poisoning.

**EPA COMPLIANCE**

**EMISSION CONTROL INFORMATION**

THIS VESSEL MEETS U.S. EPA EVM STANDARDS USING CERTIFIED COMPONENTS  
SEA HUNT BOATS MFG. CO. INC., COLUMBIA, S.C.

**TRIM TAB WARNING  
(IF EQUIPPED)**

**WARNING**

TRIM TAB MUST BE RETRACTED BEFORE LOADING OR TRAILER FAILURE TO DO SO MAY RESULT IN DAMAGE TO TRANSDUCER, TABS OR CYLINDER

**OIL DISCHARGE (>26' ONLY)**

**DISCHARGE OF OIL PROHIBITED**

THE FEDERAL WATER POLLUTION CONTROL ACT PROHIBITS THE DISCHARGE OF OIL OR OILY WASTE INTO OR UPON THE NAVIGABLE WATERS AND CONTIGUOUS ZONE OF THE UNITED STATES IF SUCH DISCHARGE CAUSES A FILM OR SHEEN UPON, OR DISCOLORATION OF THE SURFACE OF THE WATER, OR CAUSES A SLUDGE OR EMULSION BENEATH THE SURFACE OF THE WATER.

VIOLATORS ARE SUBJECT TO A PENALTY OF \$25,000

**CO WARNING- TRANSOM**

**DANGER**

Certain models (200 and above) have designed a push button and generator voltage control system and may have carbon monoxide gas (CO) detector installed. Always follow the manufacturer's instructions. Do not shut off if a person shows signs of carbon monoxide poisoning. See Dealer's Manual for information regarding carbon monoxide poisoning.

**PROP WARNING- TRANSOM**

**DANGER**

DO NOT USE BOARDING LADDER WHILE ENGINE IS RUNNING. SERIOUS INJURY OR DEATH COULD RESULT. LADDERS TO BE USED ONLY WHILE BOAT IS IN WATER.

Keep labels in good condition– contact your dealer or Sea Hunt for replacements if they become damaged or illegible.

ON-PLANE SEATING LOCATIONS ●

WITH T-TOP ●

WITH OPTIONAL REAR SEAT ●

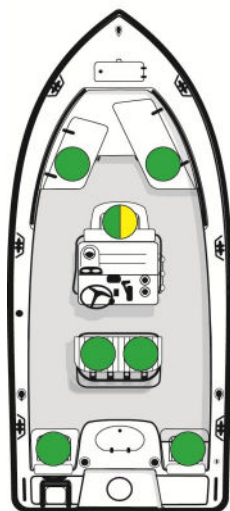

TRITON SERIES

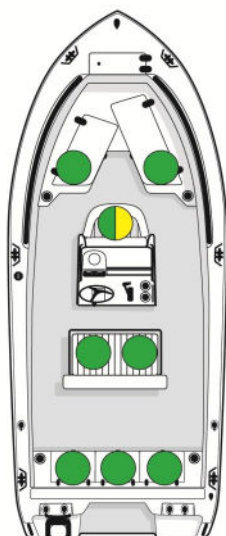

ULTRA SERIES

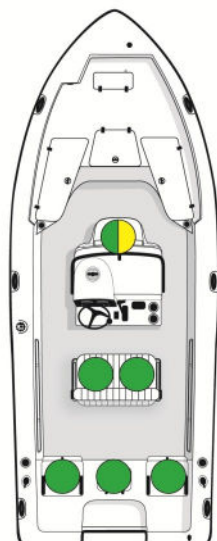

BX SERIES

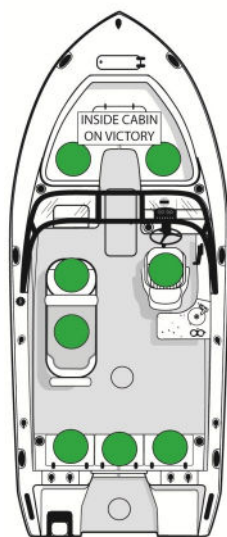

ESCAPE/VICTORY  
SERIES

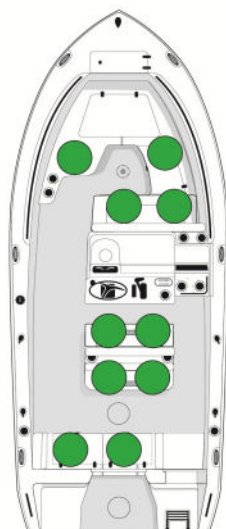

EDGE SERIES

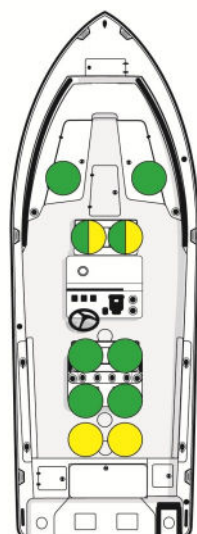

GAMEFISH SERIES

# LIMITED WARRANTY

Sea Hunt Boat Manufacturing Company, Inc. LIMITED WARRANTY

## **One-Year Limited Warranty**

(a) SEA HUNT BOAT MFG. CO., INC. (SEA HUNT) warrants to the original purchaser for a period of one year from the date of delivery to the original purchaser that each SEA HUNT boat will be free from defects in material and workmanship under normal recommended use.

(b) During this one year period, warranty repairs will be made without charge by SEA HUNT at its plant in Columbia, SC or, at SEA HUNT's option, by an Authorized SEA HUNT Marine Dealer. Transportation charges to and from the place of repair will be the responsibility of the original purchaser. All repairs made under this warranty are subject to the approval of an Authorized SEA HUNT Representative.

(c) This One-Year Limited Warranty does not apply to carpet, upholstery, gelcoat finishes, osmosis, blisters, cracks, or crazing, or to equipment and accessories not manufactured by SEA HUNT, including windshield, windshield breakage, engine or drive train, or parts which have been altered or subjected to misuse or negligence, or to the achievement of any particular level of performance.

(d) This One-Year Limited Warranty extends only to the original purchaser and may not be transferred to subsequent purchasers.

## **Ten-Year Hull Limited Warranty**

(a) SEA HUNT warrants to the original purchaser for a period of ten years from the date of delivery to the original purchaser that each SEA HUNT boat will be free from defects in material and workmanship under normal recommended use.

(b) SEA HUNT will repair or replace, at its option, any SEA HUNT hull found to have a structural defect, provided the original purchaser returns the boat to SEA HUNT at its plant in Columbia, SC, or, at SEA HUNT's option, by an Authorized SEA HUNT Marine Dealer. Transportation charges to and from the place of repair will be the responsibility of the original purchaser.

(c) This Ten-Year Hull Limited Warranty does not apply to non-structural hull surface changes, such as fading, checking, crazing, blisters, and gelcoat cracks. Further, this warranty also does not apply to hull damage caused by items not installed on the boat by SEA HUNT, accidents, neglect, unauthorized repairs, or by the boat's trailer. This warranty also does not apply to boats used for or in racing or for governmental, commercial or business use.

## **Limitation of Liability and Disclaimer**

THIS WARRANTY IS IN LIEU OF ALL OTHER WARRANTIES, EXPRESS OR IMPLIED, INCLUDING THE IMPLIED WARRANTIES OR MERCHANTABILITY AND FITNESS FOR A PARTICULAR PURPOSE. IMPLIED WARRANTIES, IF ANY, WHICH CANNOT BE DISCLAIMED, ARE LIMITED IN DURATION TO THE DURATION STATED ABOVE. ALL OTHER OBLIGATIONS OR LIABILITIES, INCLUDING LIABILITY FOR LOSS, OR CONSEQUENTIAL DAMAGES ARE HEREBY EXCLUDED. SOME STATES DO NOT ALLOW LIMITATIONS ON HOW LONG AN IMPLIED WARRANTY LASTS OR THE EXCLUSION OR LIMITATION OF INCIDENTAL OR CONSEQUENTIAL DAMAGES, SO THE ABOVE LIMITATIONS OR EXCLUSIONS MAY NOT APPLY TO YOU. THIS WARRANTY GIVES YOU SPECIFIC LEGAL RIGHTS, AND YOU MAY ALSO HAVE OTHER RIGHTS WHICH VARY FROM STATE TO STATE.

SEA HUNT reserves the right to alter models, change colors, specifications, materials, equipment, component parts and prices, or cease production of certain models at any time without notice. Such changes shall be made without incurring obligations to equip or modify units produced prior to the date of such changes.





